

7 0 0   S E R I E S

# USE & CARE

G U I D E





# INTRODUCING THE 700 SERIES

## Integrated Refrigeration

The Sub-Zero 700 Series brings you true innovation! It is the first *integrated systems approach* to domestic refrigeration, offering you three significant advantages.

- Integrated systems refrigeration gives you the choice of proportion ... of refrigeration to freezer temperatures to meet your needs. Storage below counter height level is a drawer, while storage above the counter is a cabinet. The ergonomic division of space increases your access to storage areas.

- Integrated systems refrigeration gives you the choice of location of refrigeration units throughout your kitchen and home. This helps you meet your individual needs for the way you use refrigeration within your home.
- Integrated systems refrigeration gives you total aesthetic integration with cabinets you have chosen. Refrigeration units, in essence, are refrigeration cabinets. They literally become a part of the kitchen furniture.

## Table of Contents

<b>Introducing the 700 Series</b> . . . 3	<b>General Maintenance</b>
<b>Combination Unit</b> . . . . . 4	Cleaning . . . . . 13
<b>Refrigerator Units</b> . . . . . 5	Lighting Information . . . . 14
<b>Freezer Units</b> . . . . . 6	Master Power Switch . . . . 15
<b>Features of the 700 Series</b> . . 7	90 Degree Door Stop . . . . 15
<b>Using Your Sub-Zero Unit</b>	Vacation Time . . . . . 15
The Electronic	<b>Troubleshooting</b> . . . . . 16
Control System . . . . . 8-9	<b>Keeping Food at its Best</b>
Shelves . . . . . 10	Keeping Food Fresh . . . . 17
Drawers . . . . . 10-11	Keeping Food
Door Shelves and	Safe to Eat . . . . . 17-20
Dairy Compartment . . . . . 11	Suggested Food
Deli-Drawer and Shelf . . . 12	Storage . . . . . 20-25
Glass Tray . . . . . 12	<b>Service Information</b> . . . . 26
Ice Maker . . . . . 12	
Sounds . . . . . 12	

# COMBINATION UNIT

## Model 700 TC/TCI

Your Sub-Zero 700 Series unit is protected by a warranty that is second to none. Please read it and keep this book as a reminder of the excellent protection it gives you. See page 26 for the warranty.

This use and care book is meant to answer most of the common questions you may have about the general operation of your 700 Series unit. If you have any questions that need further addressing please call 800/222-7820 for your local product distributor or Sub-Zero.

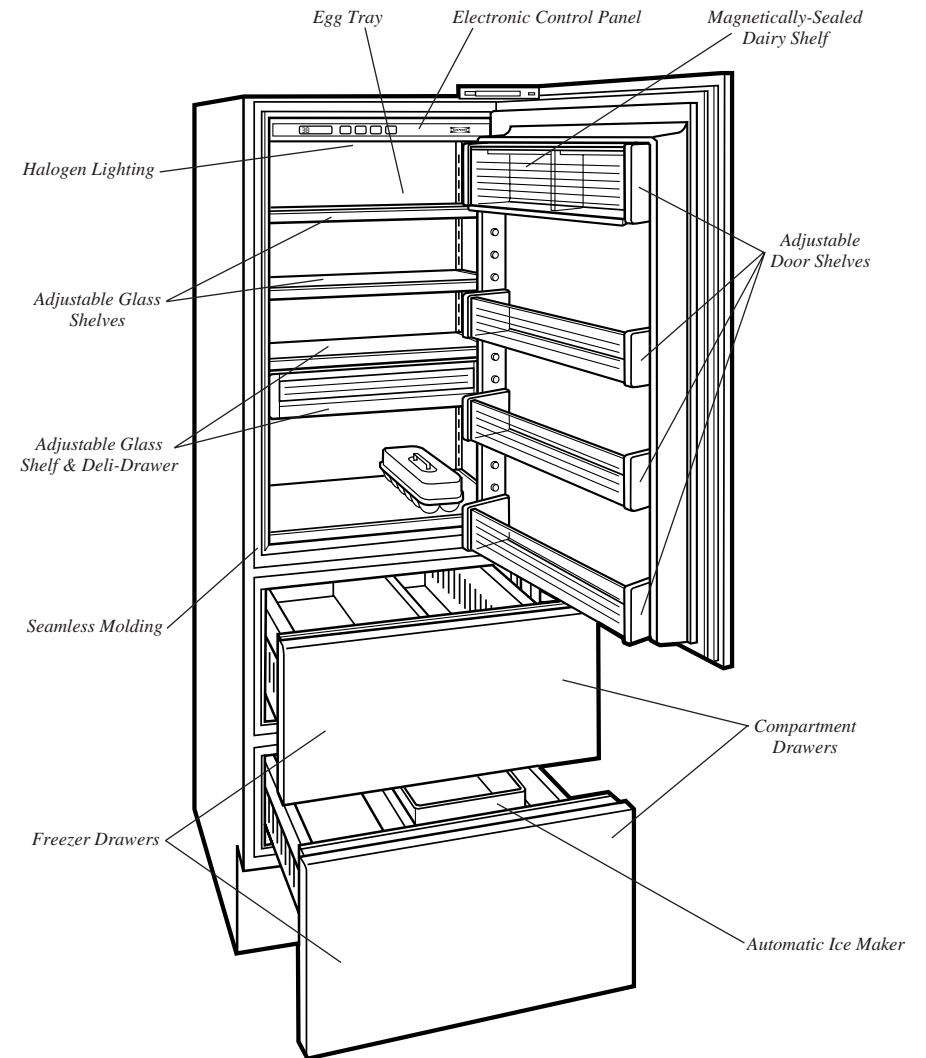

# R

# EFRIGERATOR UNITS

Model 700 TR

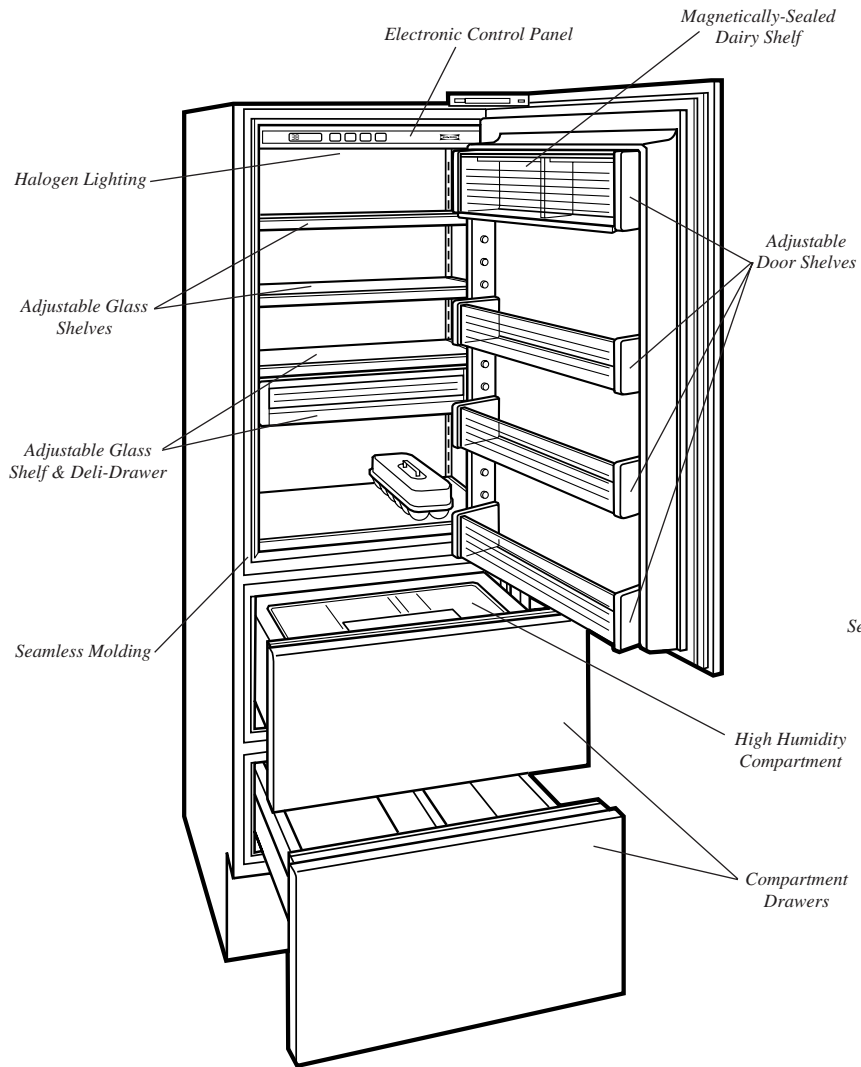

Model 700 BR

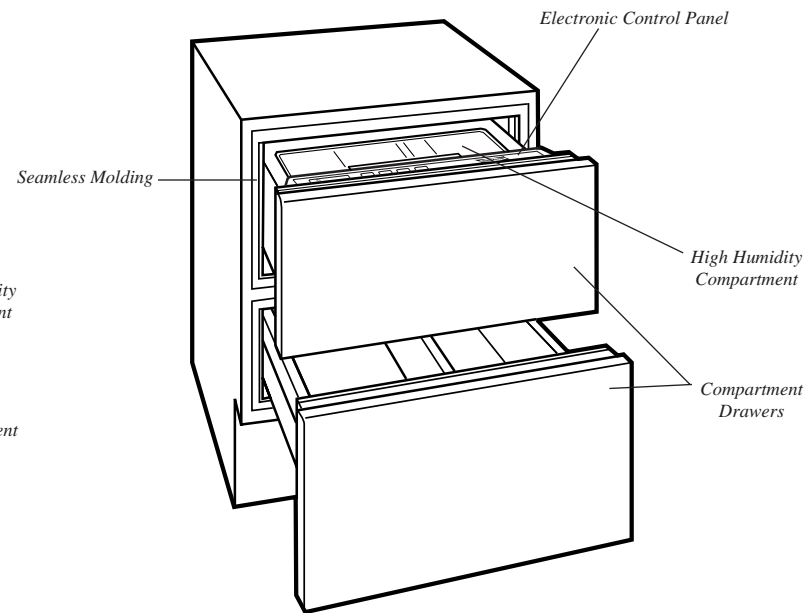

# FREEZER UNITS

Model 700 TF/TFI

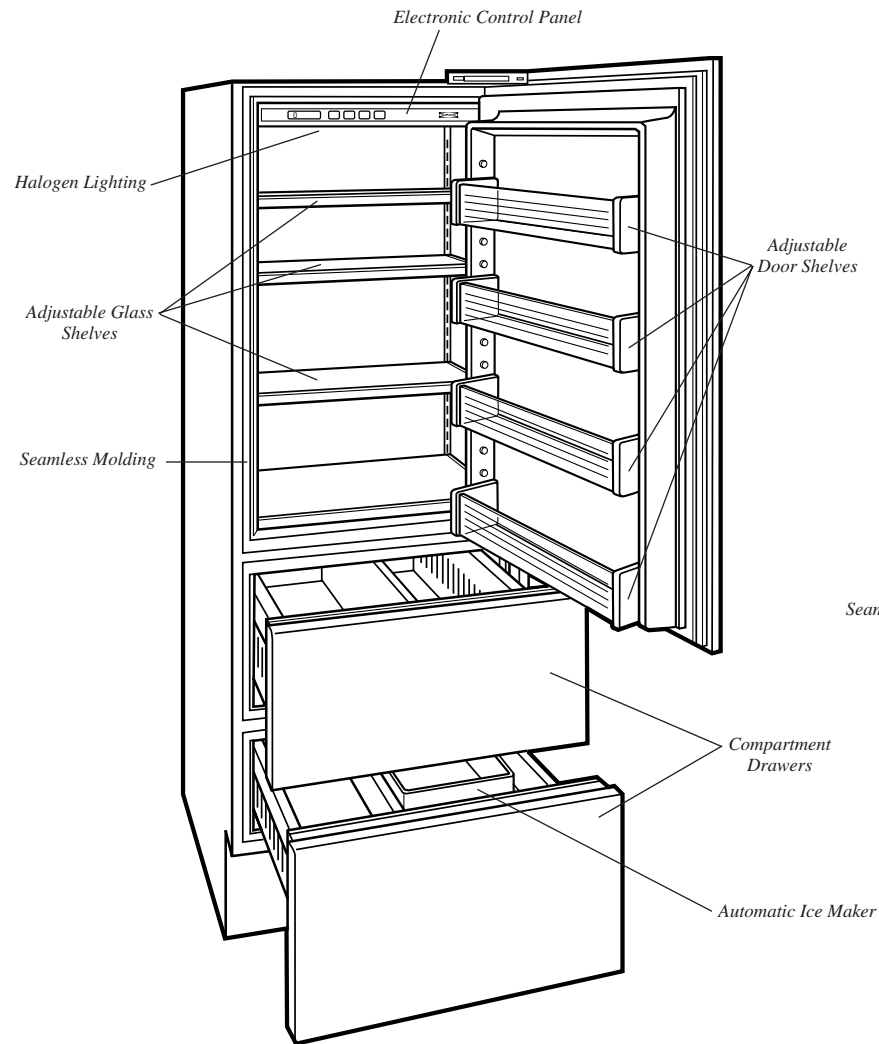

Model 700 BF/BFI

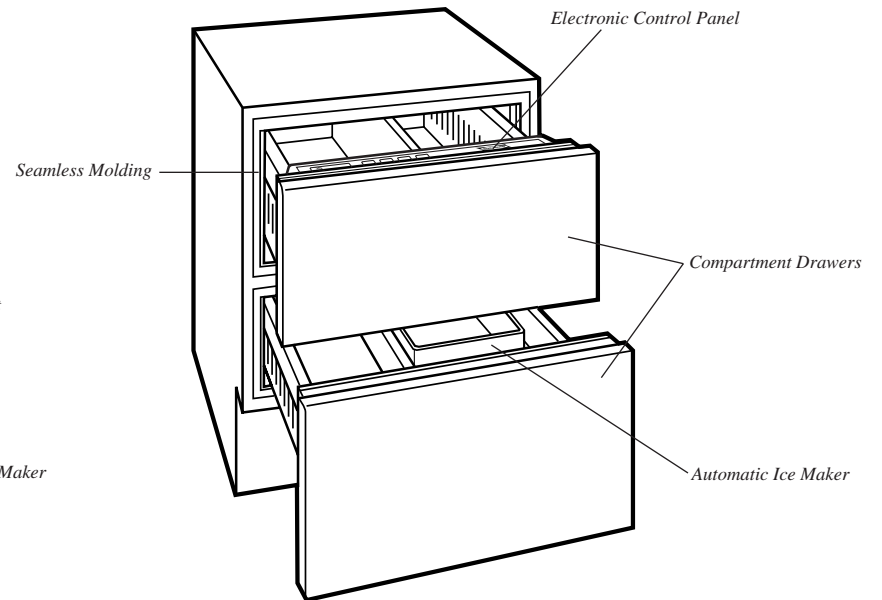

# FEATURES OF THE 700 SERIES

---

Sub-Zero's tradition of integrated design and quality continues in the 700 Series, with the following standard features.

## ***Seamless Molding***

A single piece of molding forms the complete front of each unit's interior, giving a sculptured look that is both utilitarian and elegant.

## ***Electronic Control Panel***

A microprocessor controls all electronic functions ... temperature, adaptive defrost, lights, cooling fan, and door/drawer ajar warning. The liquid crystal display (LCD) lets you monitor all temperature zones on the unit, and easily make adjustments.

## ***Halogen Lighting***

Flat to the ceiling, this superior lighting provides white, efficient light in cabinet and drawer units.

## ***Dairy Shelf***

A positive-sealing dairy compartment, divided by a small internal wall, is standard on tall refrigerator and combination units. This fully adjustable compartment is a convenient place for deli foods and small items that need a fresh environment.

## ***Adjustable Shelves***

A single sculptured molding, with tempered glass molded into it, forms each sealed, adjustable shelf. This design feature prevents spills from dripping throughout the unit.

## ***High Humidity Compartment***

An interchangeable lift-up cover provides for maximum humidity in the base and tall refrigerator units, helping you keep produce at its best quality, longer.

## ***Ice Container***

This clear, molded container is easily removable from the lower drawer. It is offered as an option on the base and tall freezer units, as well as the combination unit.

## ***Deli Drawer***

This enclosed compartment in the tall refrigerator and combination units is adjustable with the shelves. It gives you a convenient area for deli foods or other small items.

## ***Egg Tray***

A portable egg tray offers handy storage and is easily removable. It's provided with the tall refrigerator and combination units.

# USING YOUR SUB-ZERO UNIT

## The Electronic Control System

The sophisticated electronic control system provides you with the best control of your refrigerated foods. By maintaining recommended refrigerator and freezer temperatures, you can keep food safe and retain the best quality possible.

A microprocessor accurately controls the temperature of the cooling zones. It samples the temperature every second, and makes adjustments to maintain the temperature you have indicated.

The control panel is located on the top of the tall units, and in the top drawer of the base. All of the essential controls and information are displayed in this easy-to-reach-and-see panel.

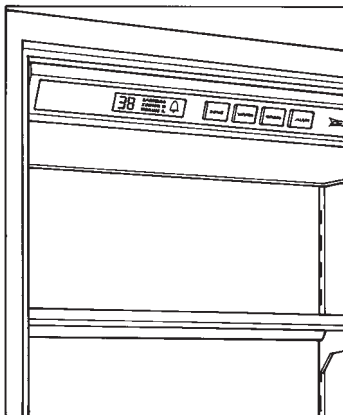

*Tall unit control panel*

### **LCD Display**

This display shows the actual temperature of different zones in your unit. The temperature and name of each corresponding zone appear every five seconds.

### **Zone Button**

By pressing this button, you can see the temperatures set in different zones of your unit. For example, if you press this button and the words “top drawer” are flashing, you will see the temperature of that zone displayed.

### **Colder Button**

This button allows you to decrease the temperature of a selected zone.

### **Warmer Button**

Similar to the colder button, you can raise the temperature in any zone by pressing this button.

### **Alarm Button**

You can turn the alarm on or off with this button, or stop it with this control once the alarm has sounded. When the alarm is activated, the bell symbol in the LCD will be visible.

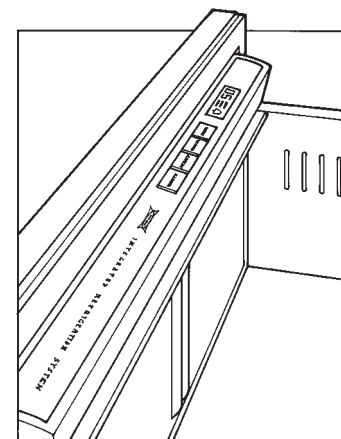

*Base unit control panel*



## *How to Adjust Temperatures*

If you need to adjust the temperature in any area of the unit, press the **zone button**, until the name of the zone you want to adjust is flashing. If you do not adjust the temperature within five seconds, the control panel will automatically go out of the set mode and continue to monitor the unit.

### *To decrease the temperature*

When the selected zone is displayed, you can decrease the temperature in that zone by one degree each time you press the **colder button**. For example, if you have selected the “cabinet” zone and a temperature of 38°F is displayed, you can decrease the temperature by pressing the colder button two times.

### *To increase the temperature*

Similar to the **decrease temperature** instructions, you can increase the temperature by one degree each time you press the warmer button for the zone you have selected.

## *Recommended Temperature Settings*

Refrigerator units are factory pre-set to maintain zones 38° Fahrenheit. The temperature range is 34°F to 45°F.

Freezer units are factory pre-set to maintain zones at 0° Fahrenheit. The temperature range is -5°F to +5°F.

To use the integrated system efficiently, set temperatures to decrease from the top cabinet to the lower drawer. A suggestion that offers great flexibility is ...

- cabinet 38°F
- upper drawer 35°F
- lower drawer 32°F

## *How to Operate the Alarm*

When your alarm is **on**, the alarm bell will be illuminated on the control panel. To turn the alarm **off**, press the alarm button one more time to make the bell disappear from the display.

# USING YOUR SUB-ZERO UNIT

## Shelves

You can remove or adjust the tempered glass shelves by tilting the shelf **up** at the front, then lifting **up and out of the tracks** on rear wall of the refrigerator or freezer, as shown in the diagram.

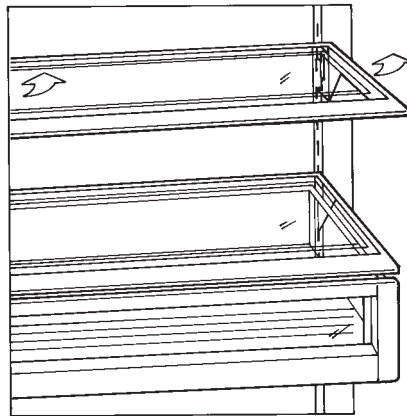

*Glass shelf removal*

To clear the door shelves, lift and tilt the right end of the shelf up, and tilt the left end down. Then lift out the shelf, clearing the unit's door shelves.

### ⚠ CAUTION

*Always exercise care when you handle the glass shelves, to prevent breakage or scratching the interior.*

To replace shelves, select the desired shelf height. Then, with the shelf front raised slightly, place shelf in tracks at the rear of the unit. Lower the front of the shelf until it locks into position.

## Drawers

To remove a drawer from your unit, pull it open until it stops. Raise the drawer front and pull out, as shown in the diagram.

To replace a drawer, raise the front of it and place onto the tracks. Be sure to engage the front holes of the drawer rail with the small pegs at the end of each rail.

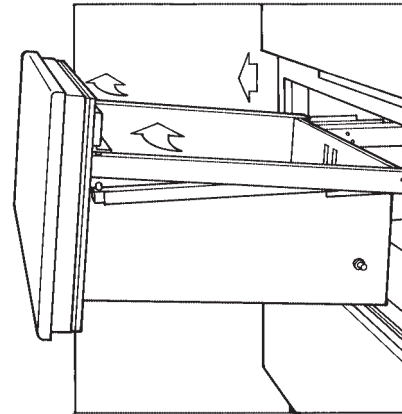

*Drawer removal*

### ⚠ CAUTION

*Where you are removing the top drawer of a base unit, you must disconnect the control cable before removing the drawer as shown in the diagram below.*

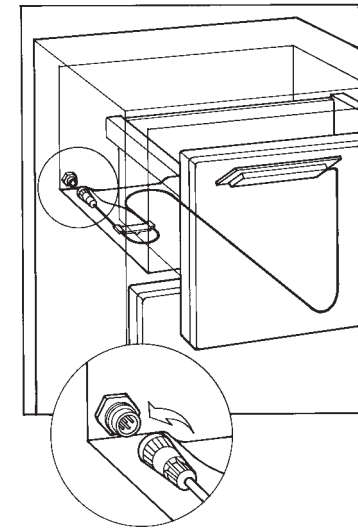

*Control cable disconnection*

### ***High Humidity Compartment***

One lift-up cover is standard with each tall and base refrigerator. You can easily remove this cover for cleaning or moving to another drawer by lifting the front edge up and pulling out from the back.

The clear-view window allows easy access and visibility of all vegetables stored in the drawer.

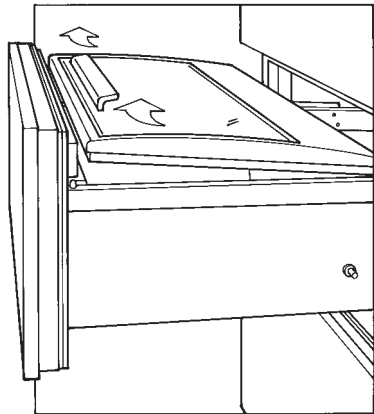

*Lift-up cover removal*

### ***Drawer Divider***

The drawer divider is easily removed by pulling forward and sliding the back edge away from the back of the drawer. Reverse the procedure as illustrated in the diagram for installation.

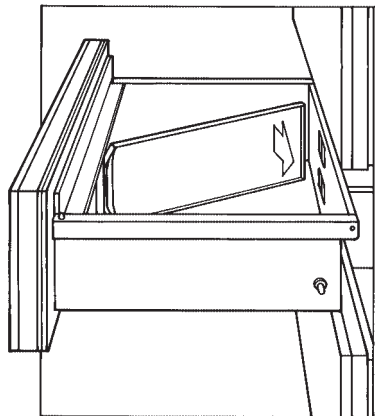

*Drawer divider insertion*

### **Door Shelves and Dairy Compartment**

The door shelves and dairy compartment are adjustable within the guides of the door liner.

To remove, lift straight up and out from the bottom.

To replace, select a desired position and push down into the guides.

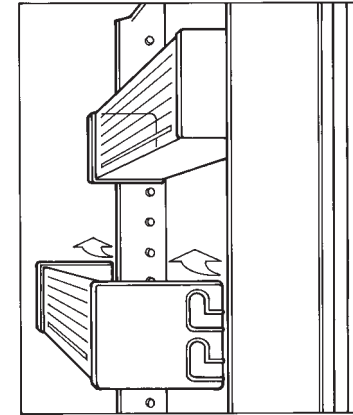

*Door shelf removal*

# USING YOUR SUB-ZERO UNIT

## Deli-Drawer and Shelf

The one piece deli-drawer and shelf assembly is easily removed for cleaning and repositioning for your use. The small deli-drawer is convenient for those small easy-to-lose items as well as to keep deli items fresh.

Remove this assembly in much the same way you remove the standard shelves in your unit. See the instructions and diagram under “Shelves”

## Glass Tray

### *Tall Units*

The glass tray, with tall units only, is packed on the top shelf of your Sub-Zero. Place this shelf on the bottom portion of the top cabinet area. It is necessary to have this glass installed properly to ensure an even flow of air through the 700 Series unit.

**IMPORTANT NOTE:** *Do not place food or packages close to the edges of the walls.*

## Ice Maker

### *Freezer Units*

The ice maker in your Sub-Zero is fully automatic and has been factory pre-tested. To put into operation it requires only a connection to the house water supply. The ice maker shuts off when you remove the ice storage container from the freezer. When you replace the container, the ice maker will resume producing ice.

**IMPORTANT NOTE:** *When you fill the first ice bucket with ice, you should toss this supply out. In any new connection, there may be dirt in the ice.*

## Sounds

Certain noises may be evident with the normal operation of the unit. Surrounding acoustics like walls, floors and cabinets may affect the sound level of your unit.

# GENERAL MAINTENANCE

## Cleaning

Like all kitchen appliances, it is necessary to keep your 700 Series unit clean to ensure a smoother operating unit and keep food safe. Clean any spills on the interior with a mild solution of soap and warm water. Do not use abrasive cleaners as these may scratch interior surfaces.

### Condenser

#### ⚠ WARNING

*For maintenance and cleaning, we recommend the circuit breaker or master power switch to the unit be shut off.*

**IMPORTANT NOTE:** *To ensure efficient performance of your 700 Series unit, your condenser must be cleaned regularly. Clean it every three months under normal use.*

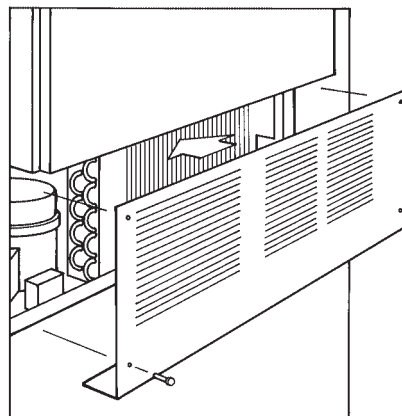

Condenser location

To clean the condenser area, remove the screws holding the toe kick in place. The toe kick plate will slide forward easily, giving you access to the condenser area. Use a soft bristle brush and vacuum hose to remove the accumulation of dust and lint particles. If you have pets in your home, you may want to clean the condenser area more often than once every three months.

### Shelves

All refrigerator and freezer compartment glass shelves are dishwasher safe and may be cleaned in this manner. However, you can also clean them with a mild solution of soap and warm water. Rinse and dry thoroughly.

#### ⚠ CAUTION

*Do not submerge or pour hot water over cold glass shelves. Allow them to come to room temperature before cleaning. Extreme temperature may cause the glass to break.*

# GENERAL MAINTENANCE

## Lighting Information

You will quickly notice the absence of any light switches on your 700 Series unit. In the upper cabinet portion of a tall unit, the switch is mounted to the interior of the door itself and as it passes a point in closing, it breaks a circuit enabling the light to go out.

Switches in the drawer compartment are mounted on the right side of the drawer area. In some instances the drawer switch may interfere with the safe closing of a drawer. If this occurs, merely move the switch to the raised position and try closing the drawer again. **Do not force the drawer to close.**

### Light Bulb Replacement

#### ⚠ CAUTION

*For your safety, the circuit breaker to the unit should be shut off or turn off the master power switch before replacing bulbs. Protective gloves should be worn when handling bulbs.*

#### Top Compartment

If you need to replace a 35 watt halogen light in the tall unit's top cabinet, you must open the control panel area.

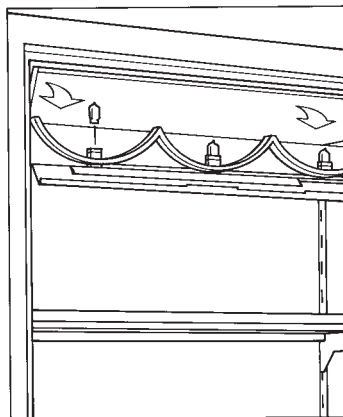

*Light bulb replacement in tall unit's top cabinet.*

Do not pull the panel down from the center. Instead, grasp the edges of the control panel and pull down. Two tabs on each corner will release, enabling the panel to drop down.

#### ⚠ WARNING

*The halogen lights may be very hot and may burn you. Use a soft cloth or protective gloves. Grasp the bulb firmly and pull straight up.*

Follow the reverse steps in replacing the bulb and positioning the control panel.

#### Drawer Compartment

To replace a light bulb in the drawer compartment, you must pull the drawer out to its maximum extension. You may find it easier to remove the entire drawer. Refer to page 10 for drawer removal procedures.

Slide the glass lens to the left, revealing the 20 watt halogen light bulb. Remove the bulb by pulling straight out and complete the reinstallation by following the reverse of these steps.

#### ⚠ WARNING

*To prevent a possible burn, grasp the bulb with a soft cloth or protective gloves.*

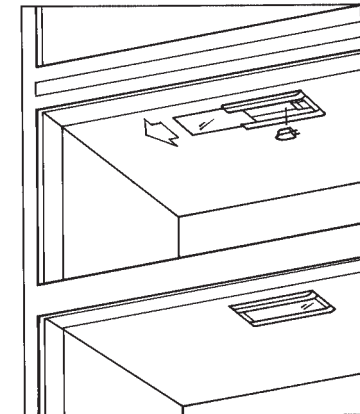

*Light bulb replacement in drawer compartment.*

## Master Power Switch

All 700 Series units have a master power switch. The switch, located behind the toe kick plate, will turn off all electrical power to the equipment. This switch can be used for shutting down the unit for servicing or extended vacations.

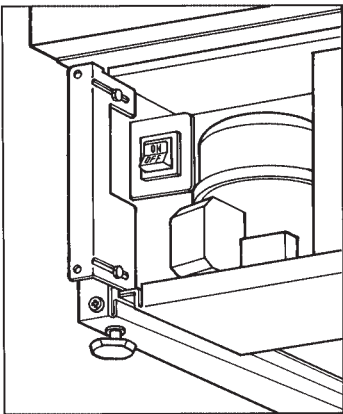

Master power switch.

## 90 Degree Door Stop

Your tall 700 Series unit is equipped with a built-in 90 degree door stop for the top compartment.

You can easily actuate the stop by using a blade-type screwdriver and advancing the brass fitting in both the top and bottom hinges.

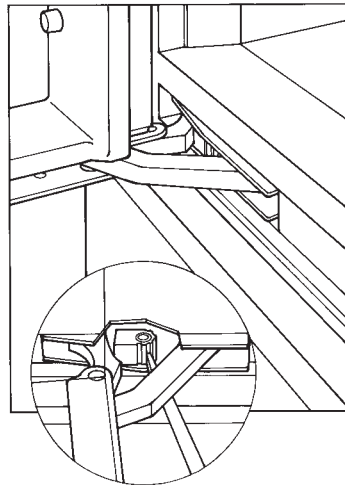

Actuating the 90° degree door stop.

You must actuate both stops at 90 degrees if you want to safely use the door.

You can go to the maximum of 119 degree opening by using the screwdriver and advancing the brass cam to the next stop.

### **▲ WARNING**

*The door swing on the tall 700 Series unit may cause severe finger pinching or damage to the unit. Watch that fingers are not placed in the door opening on the hinge side when the door is open.*

*Also, when the door is open to 119 degrees, the door panel, depending on its thickness, may strike the face frame of the Sub-Zero unit causing serious damage.*

## Vacation Time

For extended vacations, either turn off your Sub-Zero or shut off the circuit breaker. Empty all contents in the unit and block the doors open slightly. A one inch space is sufficient for letting fresh air in to keep the interior dry.

During short vacations, you should remove all perishable items and leave the temperature settings at their set point.

If for any reason this unit is put into service on a temporary basis, and later shut off, the doors should be blocked open to allow fresh air to circulate with the compartments. Also, the circuit breaker to the unit should be shut off.

# TROUBLESHOOTING

## *If refrigerator/freezer is not operating–*

- Is there electrical power to equipment?
- Is home fuse blown or circuit breaker off?
- Is refrigerator/freezer control off?
- Is your condenser clean?
- If still not running, unit may be in defrost; wait 30 minutes to see if unit will restart.

## *If refrigerator/freezer is warmer than usual–*

- Is control set properly?
- Has door been open too long?
- Have you recently added a large quantity of food?

## *If refrigerator/freezer runs too much–*

- Is condenser clean?
- Has door/drawer been open for extended time or large amounts of food added?

## *If refrigerator/freezer is frosted up–*

- Has door been left open?
- Are doors closing and sealing properly?

## *If condensation forms inside the unit–*

- This is normal during high humidity and frequent door openings.

## *If condensation forms on the outside–*

- Be sure door/drawer is closed and gasket is sealing.

## *If there is odor in the unit–*

- Completely clean the product.
- Cover all food tightly.

## *If light bulb needs replacing–*

### **▲ WARNING**

*Turn off circuit breaker to Sub-Zero, wear gloves to protect against broken glass or burns.*

## *LCD display board warnings–*

- If the following numbers of flashing words appear in the LCD display board, you should keep the door/drawer closed as much as possible and call your Sub-Zero service center for assistance.
- 20 displayed and indicator flashing
- 55 displayed and indicator flashing
- Su displayed and top lights off
- -88 displayed, top lights off and buttons do not operate
- buttons do not operate and top lights are off



# KEEPING FOOD AT ITS BEST

## Keeping Food Fresh

Your Sub-Zero unit is the most advanced refrigeration system available to help keep food fresh, and keep it safe to eat.

But the quality and safety of your food depends not only on having the best refrigeration system. It also depends on *you* and how you handle your food.

The information in this section gives you the most current food handling and storage recommendations to help you keep food at its best. If you have specific questions that are not addressed here, contact your University or County Extension Service, or the USDA Meat and Poultry Hotline – Mon.-Fri. 10am - 4pm EDT, 800-535-4555.

Most food deteriorates over time. That is inevitable. From the time it is harvested, slaughtered, or manufactured, until it is consumed, food undergoes changes. Microorganisms (bacteria, yeasts and molds) get into food, multiply in number, and cause spoilage. Enzymes that occur naturally in food continue the ripening process, even after the food is harvested. Improper temperatures cause food to deteriorate faster. Changes in humidity cause wilting and shriveling that can lead to spoilage.

But good handling practices can *minimize* the rate of changes in food. Here's what you can do...

- Follow the recommended storage times and temperatures in the following pages of this booklet. Your Sub-Zero unit accurately maintains temperatures in different temperature zones, helping to slow the growth of food spoilage microorganisms, and to slow the ripening process.
- Use specially designed compartments for dairy foods, deli foods, and fresh produce. These compartments maintain temperature and humidity levels that keep foods fresh.
- Rotate food in refrigeration units, using a “first-in-first-out” system.

## Keeping Food Safe to Eat

When food does spoil, it's usually obvious. It becomes moldy, has an off-odor, looks rotten, slimy, or discolored. But there are times when it may not be so obvious.

***As a general rule, if you think a food has been stored too long and may be spoiled, discard it.*** Don't taste it to check and see if it's ok. While the bacteria that cause this kind of food spoilage will not cause foodborne illness, or food poisoning, taste-testing is not a recommended practice. ***When in doubt, throw it out.***

Most foodborne illness, often called food poisoning, is preventable. It can be prevented by following some basic rules... ***keep food either hot or cold, and keep everything that touches food clean.***

# KEEPING FOOD AT ITS BEST

## Keeping Food Safe to Eat

Foodborne illness is caused by bacteria such as staphylococcus aureus, salmonella, clostridium, perfringens, e coli, and clostridium botulinum. These bacteria grow rapidly at temperatures between 40°F and 140°F, a range that's called the Danger Zone. ***Food should never be left in the Danger Zone for more than two hours.*** When the bacteria have multiplied to the millions in warm temperatures, they cause illness. Some bacteria cause flu-like symptoms, while others cause serious illness or become fatal. ***Young children, the elderly, and people who are already ill are more likely to become sick from food poisoning.***

To reduce your risk for food-borne illness, use the following techniques to keep your food safe to eat.

### *When You're Shopping*

- Place packages of raw meat, seafood or poultry in plastic bags to keep them from dripping on other foods.
- Shop for meat, seafood and poultry ***last***. Don't leave these foods in a hot car when you have finished shopping. Take along a cooler in hot weather or when you have to travel long distances.
- Check "use-by" or "sell-by" dates on foods to make sure they are fresh.
- Use extra care when buying deli food. Buy only the amount you will use in 1-2 days. Discard any hot or cold deli food that may have been at room temperatures for more than two hours.

### *When You Store Food*

Monitor temperatures of refrigeration zones on the electronic control panel of your Sub-Zero unit. Refrigerator temperature should be kept at 45°F or below, and freezer temperature should be kept at 0°F.

Follow the recommended refrigerator and freezer storage times and temperatures on pages 21-25.

Store raw meat, poultry and seafood separate from other foods. Keep juices from these packages from dripping on other food.

Never taste food that looks or smells strange to see if you can still use it. ***Discard it.***

For refrigerator storage, leave raw meat, poultry and seafood in its original wrapper unless it is torn. ***Repeated handling can introduce bacteria to these foods.***

For freezer storage, use freezer wrap, freezer-quality plastic bags, or aluminum foil over the commercial wrap if foods will be stored in the freezer for more than a couple of months. This minimizes dehydration and quality loss. ***Date and label all packages.***

### ***When You Store Food***

Food stored in refrigerator units should be wrapped in foil or plastic wrap, or placed in plastic bags or airtight containers to keep it from drying out. ***Date and label all packages.***

Food stored in freezer units should be wrapped in freezer wrap, or placed in freezer-quality plastic bags or freezer containers. (Single layers of aluminum foil may not be adequate—this wrap can develop holes and cause freezer burn.) ***Date and label all packages.***

### ***When You Prepare Food***

***Clean everything that comes in contact with food.***

- Wash your hands for 20 seconds before and after handling food.
- Sanitize counters, equipment and utensils after handling raw meat, seafood or poultry. Rinse with a dilute chlorine bleach solution—2 teaspoons/1 quart of water.

Use clean kitchen towels, sponges and cloths. Replace sponges every few weeks.

Use disposable plastic gloves if you have an infected cut or burn on your hands.

Thaw food in the refrigerator or microwave, not on the counter. When you thaw food in a microwave oven, you should cook it immediately.

Marinate food only in the refrigerator. Do not save the marinade to use again.

Rinse poultry and seafood in cold water before cooking.

***Avoid cross contamination in preparing food.*** Keep raw meat, poultry, and seafood and their juices away from other food. For example, don't use the same surface and utensils for preparing raw meat, poultry and seafood as you would for preparing salad ingredients.

Thoroughly clean your cutting boards (plastic and wooden). Wash with hot water and soap, and rinse with a dilute chlorine bleach solution—2 teaspoons/1 quart of water.

# KEEPING FOOD AT ITS BEST

## Keeping Food Safe to Eat

### *When You Cook Food*

Don't taste raw or partially cooked meat, poultry, eggs or fish.

Cook meat to an internal temperature of 165°F or above, poultry to 180°F or higher. For cuts more than two inches thick, use a meat thermometer to check the temperature. For thinner cuts, clear juices (not pink) are signs of doneness.

If you are cooking frozen meat or poultry that has not been defrosted, increase the cooking time to 1 1/2 times the time required for thawed items.

Roast meats or poultry in oven temperatures of 325°F or above.

Cook eggs until the yolk and white are firm, not runny. Don't use recipes in which eggs remain raw or partially cooked.

If your microwave has a temperature probe, use it. Check temperatures of meat and poultry in at least three spots. Rotate foods during microwaving.

### *When You Have Leftovers*

Refrigerate or freeze cooked leftovers in small, covered containers within 2 hours after cooking. Make sure there is adequate air space around containers, so food can cool down more quickly.

If you cook a large amount of food for serving later, divide it into smaller portions or cool in shallow pans so that it cools quickly.

Remove stuffing from meat or poultry; store it separately.

Date packages of leftovers and use within a safe period of time.

Cover and reheat leftovers thoroughly before serving. Bring sauces, soups and gravy to a boil. Heat other foods to 165°F.

If you think a food may have spoiled, discard it. ***When in doubt, throw it out.***

## Suggested Food Storage

The time limits for refrigeration will help keep food from spoiling or becoming dangerous to eat. The time limits for frozen foods are to maintain flavor and texture. If food is kept longer than the recommended time in the freezer, it will still be safe to eat, but the quality won't be as good.

<b><i>Meat, Fish, Poultry</i></b>		<b>Recommended storage temperature in degrees F</b>	<b>Approximate storage life at refrigerator temperatures</b>	<b>Recommended storage time in freezer at 0°F</b>	<b>Comments</b>
<b>Food</b>	<b>Form</b>				
<b><i>Fresh Fish and Seafood</i></b>	cod, flounder, haddock, sole bluefish, perch, mackerel, salmon shrimp oysters	32 32 32 32	2 days 2 days 4 days 1 day	6 months 2-3 months 5-9 months 4 months	<i>Freeze in original wrap up to 2 weeks. Use freezer wrap, freezer-quality plastic bags, or aluminum foil over the commercial wrap if foods will be frozen for more than a couple of months.</i>
<b><i>Fresh Meat</i></b>	beef steaks, roasts lamb chops, roasts pork and veal chops, roasts variety meats (tongue, liver, etc.)	32-35 32-35 32-35 32-35	3-5 days 3-5 days 3-5 days 1-2 days	6-12 months 6-9 months 4-6 months 3-4 months	<i>Freeze in original wrap up to 2 weeks. Use freezer wrap, freezer-quality plastic bags, or aluminum foil over commercial wrap if foods will be stored in the freezer for more than two months.</i>
<b><i>Hamburger, Ground and Stew Meats</i></b>	hamburger, stew meats, ground turkey, veal, pork, lamb, and mixtures	32-35	1-2 days	3-4 months	<i>Freeze in original wrap up to 2 weeks. Use freezer wrap, freezer-quality plastic bags, or aluminum foil over commercial wrap if foods will be frozen for more than a couple of months.</i>
<b><i>Hotdogs and Lunch Meats</i></b>	hotdogs, opened package unopened package lunch meats, opened package unopened package	32-35 32-35 32-35 32-35	1 week 2 weeks 3-5 days 2 weeks	in freezer wrap, 1-2 months	<i>Check "sell by" dates. Do not use more than one week after this date.</i>
<b><i>Bacon and Sausage</i></b>	bacon sausage (pork, beef, turkey), raw smoked breakfast links, patties hard sausage - pepperoni, jerky sticks	32-35 32-35 32-35 32-35	7 days 1-2 days 7 days 2-3 weeks	1 month 1-2 months 1-2 months 1-2 months	<i>Keep wrapped, store at recommended refrigerator temperatures.</i>
<b><i>Ham and Corned Beef</i></b>	corned beef ham, whole ham, half ham, slices	32-35 32-35 32-35 32-35	5-7 days 7 days 3-5 days 3-4 days	1 month 1-2 months 1-2 months 1-2 months	<i>For freezer storage, drain juices.</i>
<b><i>Fresh Poultry</i></b>	chicken or turkey, whole chicken or turkey, pieces duck or goose	32-35 32-35 32-35	1-2 days 1-2 days 1-2 days	1 year 9 months 6 months	<i>Freeze in original wrap up to 2 weeks. Use freezer wrap, freezer-quality plastic bags, or aluminum foil over commercial wrap if foods will be stored in the freezer for more than two months.</i>

# KEEPING FOOD AT ITS BEST

<i>Fresh Fruits</i>	Recommended storage temperature in degrees F	Approximate storage life at refrigerator temperatures	Recommended storage time in freezer at 0°F	Comments
apples	34-40	3-6 months	See food preservation books/guides for complete instructions on freezing fruits.	<p><i>Wash and dry most fruits, store in crisper compartment. (Do not wash berries and cherries until you are ready to use them, however.)</i></p> <p><i>Fully ripe fruits should be stored in the refrigerator at recommended temperatures, to slow down the ripening process.</i></p> <p><i>Unripe fruits should be left to ripen at room temperature, in a container that allows for air circulation.</i></p> <p><i>To hasten the ripening process, you can place unripe fruit in a paper bag that has holes poked in it. Close the bag and set it on a counter. The fruit will produce ethylene, a gas that initiates the ripening process. Check the bag each day.</i></p> <p><i>Most fruits should be stored in lower humidity.</i></p> <p><i>Discard any fresh fruits that are moldy or have other signs of spoilage, and wipe out the refrigerator compartment.</i></p> <p><i>See page 24 for a list of ethylene sensitive and ethylene producing vegetables and fruits.</i></p> <p><i>✓ indicates fruit that is sensitive to chill injury, a cause of spoilage. Damage may not be apparent until the fruit is returned to a warmer temperature.</i></p>
apricots	34	1-2 weeks		
asian pears	34	5-6 months		
✓avocados	40	2-4 weeks		
blackberries	34	2-3 days		
blood oranges	40-44	3-8 weeks		
blueberries	34	10-18 days		
✓cantaloupe	36-40	10-14 days		
cassavas	34	1-2 months		
cherries, sweet	34	2-4 weeks		
clementines	40	2-4 weeks		
✓cranberries	36-40	2-4 months		
figs, fresh	34	7-10 days		
✓grapefruit	50-60	4-6 weeks		
grapes	34	8-12 weeks		
✓guavas	40-50	2-3 weeks		
honeydew	45-50	3-4 weeks		
kiwifruit	34	4-6 weeks		
kumquats	40	2-4 weeks		
✓lemons	50-55	1-5 months		
✓limes	48-50	3-5 weeks		
lychees	35	3-5 weeks		
✓mangoes	50	2-3 weeks		
nectarines	34	2-4 weeks		
✓oranges	34-48	3-8 weeks		
✓papayas	45-55	1-3 weeks		
peaches	34	2-4 weeks		
pears	34	2-3 weeks		
persimmons	34	3-4 months		
✓pineapple	45	2-5 weeks		
plums/prunes	34	2-4 weeks		
✓pomegranates	40	2-3 months		
quinces	34	2-3 months		
raspberries	34	2-3 days		
rhubarb	34	2-3 weeks		
strawberries	34	5-10 days		
tangerines	40	2-4 weeks		
✓watermelon	45-55	2-3 weeks		

<b>Fresh Vegetables</b>				
<b>Form</b>	<b>Recommended storage temperature in degrees F</b>	<b>Approximate storage life at refrigerator temperatures</b>	<b>Recommended storage time in freezer at 0°F</b>	<b>Comments</b>
anise	34-36	2-3 weeks	See food preservation books/guides for complete instructions on freezing vegetables.	<p><i>Wash vegetables in cool water and drain. Store in air-tight container or plastic wrap.</i></p> <p><i>Most vegetables should be stored in higher humidity.</i></p> <p><i>See page 24 for a list of ethylene sensitive and ethylene producing vegetables and fruits.</i></p> <p><i>Discard any fresh vegetables that are moldy or have other signs of spoilage, and wipe out the refrigerator compartment.</i></p> <p><i>For fresh-cut produce, follow storage directions on package.</i></p> <p><i>✓indicates vegetables that are sensitive to chill injury, a cause of spoilage. Damage may not be apparent until the vegetables are returned to a warmer temperature.</i></p>
artichokes	34	1-2 weeks		
asparagus	34-35	2-3 weeks		
✓beans, green/snap and lima	40-45	10-14 days		
bean sprouts	34	7-9 days		
beets	34	3-5 months		
belgian endive	36-38	2-4 weeks		
bok choy	34	3 weeks		
broccoli	34	1-2 weeks		
brussels sprouts	34	3-5 weeks		
cabbage	34	3-6 months		
carrots	34	1-5 months		
cauliflower	34	3-4 weeks		
celeriac	34	6-8 months		
celery	34	2-4 weeks		
chinese broccoli	34	10-14 days		
chinese cabbage	34	2-3 months		
corn, sweet	34	4-6 days		
✓cucumbers	45-50	1-2 weeks		
daikon	34	4 months		
✓eggplant	45-50	1-2 weeks		
endive/escarole	34	2-3 weeks		
garlic	34	3-6 months		
✓ginger root	55	6 months		
horseradish	34	10-12 months		
jerusalem artichokes	34			
✓jicama	55-65	4-5 months		
kale	34	1-2 months		
kohlrabi	34	10-14 days		
leeks	34	2-3 months		
lettuce	34	2-3 months		
mushrooms	34	2-3 weeks		
✓okra	45-50	1-2 weeks		
onions, bulb	34	1-6 months		
onions, green	34	7-10 days		
parsley	34	1-2 months		
parsnips	34	4-5 months		
peas, pods and shelled	34	7-10 days		
✓peppers, bell	45-50	12-18 days		
peppers, chile	45-50	2-3 weeks		
potatoes	40-50	2-4 months		

# KEEPING FOOD AT ITS BEST

<i>More Fresh Vegetables</i>	Recommended storage temperature in degrees F	Approximate storage life at refrigerator temperatures	Recommended storage time in freezer at 0°F	Comments
Form				
✓pumpkins	38-55	3-4 months	See food preservation books/guides for complete instructions on freezing vegetables.	✓ <i>indicates vegetables that are sensitive to chill injury, a cause of spoilage. Damage may not be apparent until the vegetables are returned to a warmer temperature.</i>
radicchio	34	2-3 weeks		
radishes	34	3-4 weeks		
romaine	34	2-3 weeks		
rutabagas	34	4-6 months		
salsify	34	2-4 months		
shallots	34	6 months		
snow peas	34	1-2 weeks		
spinach	34	1-2 weeks		
✓squash, summer	40-50	1-2 weeks		
squash, winter	50-55	3-5 months		
✓sweet potatoes	55-60	4-7 months		
✓tamarillos	37-40	2 months		
✓tomatoes (ripe)	34-40	3-4 weeks		
turnips	34	4-5 months		
water chestnuts	34-36	1-2 months		
watercress	34	2-3 weeks		

Don't store ethylene producers...	with foods that are sensitive to ethylene
apples	unripe bananas
apricots	green beans
avocados	belgian endive
ripening bananas	broccoli
cantaloupe	brussels sprouts
cherimoyas	cabbage
figs	carrots
guavas	cauliflower
honeydew	chard
kiwifruit	cucumbers
mamey sapote	eggplant
mangoes	unripe kiwifruit
mangosteen	leafy greens
nectarines	lettuce
papayas	okra
passion fruit	parsley
peaches	peas
pears	peppers
persimmons	spinach
plantains	squash
plums	sweet potatoes
prunes	watercress
quince	watermelon
tomatoes	

## Suggested Food Storage

### *Food safety ... food quality*

The food storage charts on pages 21-25 give you specific information to help you keep food safe and keep it at its best quality. The recommended storage temperatures will help you provide **optimal** storage conditions, to help you keep food at its best quality longer. As a general rule, food that requires refrigeration that is handled properly and kept at temperatures below 45° F will

be safe to eat. Storing food at temperatures below 45° F keeps it out of the Danger Zone.

The storage times for refrigeration will help keep food from spoiling or becoming dangerous to eat. The time limits for frozen foods are to maintain flavor and texture ...if food is kept longer than the recommended time in the freezer, it will still be safe to eat, but the quality won't be as good.

### *Ethylene*

Some fruits and vegetables will produce ethylene, a gas that initiates the ripening process. Ethylene can cause premature ripening in some foods, while in others, it can actually cause damage. To reduce unnecessary spoilage of your produce, do not store ethylene producing fruits and vegetables with those that are sensitive to it.



<b><i>Eggs and Deli Foods</i></b>		<b>Recommended storage temperature in degrees F</b>	<b>Approximate storage life at refrigerator temperatures</b>	<b>Recommended storage time in freezer at 0°F</b>	<b>Comments</b>
<b>Food</b>	<b>Form</b>				
<i>Eggs</i>	fresh, in shell	32	3 weeks	don't freeze	Keep fresh eggs refrigerated.  Don't eat hard-cooked eggs that have been at room temperature for more than two hours.
	hardcooked	32-35	1 week	don't freeze well	
	liquid pasteurized or egg substitutes-	32-35	3 days	don't freeze	
	opened	32-35	10 days	1 year	
<i>Deli Foods</i>	thinly sliced lunch meats	32-35	1-2 days	these do not freeze well	Check use-by or sell-by dates If you are going to freeze any of these foods, freeze immediately ... not after they have been held in the refrigerator.
	egg, chicken, tuna, ham, macaroni salads	32-35	3-5 days		
	pre-stuffed chops, chicken breasts	32-35	1 day		
	store-prepared convenience meals	32-35	1-2 days		
<b><i>Milk, Cheese, Dairy Foods</i></b>					
	butter	32-35	3 months	1 year	Check sell-by dates.  Store cheese in original packaging until ready to use. After opening, re-wrap tightly in plastic wrap or aluminum foil.  Thaw frozen cheese in the refrigerator to reduce crumbling.
	cheese-cottage or ricotta	32-35	1-2 weeks	4 weeks	
	cream cheese	32-35	2 weeks	6-8 months	
	natural (cheddar, brick, etc.)	32-35	3-6 months		
	process cheese	32-35	3-4 weeks	6-8 months	
	grated Parmesan or Romano	32-35	1 year		
	yogurt	32-35	1 month		
	whole, lowfat or skim milk	32-35	1-2 weeks		
<b><i>Leftovers, Soups, Stews</i></b>					
<i>Meat Leftovers</i>	cooked meat and meat dishes	32-35	3-4 days	2-3 months	Refrigerate or freeze leftovers in covered shallow containers within 2 hours after cooking. Reheat leftovers to 165° F.
	gravy and meat broth	32-35	1-2 days	2-3 months	
<i>Leftover Cooked Poultry</i>	fried or plain pieces of chicken	32-35	3-4 days	4 months	Refrigerate or freeze leftovers in covered shallow containers within 2 hours after cooking. Reheat leftovers to 165° F.
	cooked poultry dishes	32-35	3-4 days	4-6 months	
	pieces covered with broth, gravy	32-35	1-2 days	6 months	
	chicken nuggets, patties	32-35	1-2 days	1-3 months	
<i>Soups and stews</i>	vegetable or meat added	32-35	3-4 days	2-3 months	Reheat to at least 165° F before eating.

# SERVICE INFORMATION

## Service

### *If you need service...*

Take the necessary steps to preserve food in your unit. Door/drawers should be left closed as much as possible when unit is back in service. Please have model and serial number available (*look for them on the left-hand side of the top drawer compartment*). Call your nearest Sub-Zero Factory Authorized Service Center in your area, your dealer or Sub-Zero Freezer Company, P.O. Box 44130, Madison, WI 53744-4130. Telephone 800/222-7820.

For installation questions or general product operating information call 800/222-7820 for your local product distributor or Sub-Zero.

### “Sub-Zero Protection Plan”

#### *Full 5 Year Warranty and Limited 6th Through 12th Year Warranty on the Sealed System*

#### *Full 2 Year Warranty on Total Product*

##### *Full Five Year Warranty*

For five years from the date of original installation, your Sub-Zero warranty covers all parts and labor to repair or replace any components that prove to be defective in materials or workmanship in the sealed system. The sealed system consists of the compressor, condenser, evaporator, drier and all connecting tubing.

##### *Full Two Year Warranty*

For two years from the date of original installation, your Sub-Zero warranty covers all parts and labor to repair or replace any part of the product which proves to be defective in materials or workmanship.

##### *Limited 6th Through 12th Year Warranty*

From the 6th through the 12th year from the date of original installation, your Sub-Zero warranty covers all parts that prove to be defective in materials or workmanship in the sealed system (parts only). The sealed system consists of the compressor, condenser, evaporator, drier and all connecting tubing.

##### *Terms Applicable To Each Warranty*

All service provided by Sub-Zero under the above warranty must be performed by authorized Sub-Zero service representatives, unless otherwise specified by Sub-Zero. Service will be provided in the home during the normal business hours. This warranty applies only to products installed for normal residential use. Details regarding a non-residential warranty are available upon request.

The warranty applies only to products installed in any one of the fifty states of the United States, the District of Columbia or the ten provinces of Canada. This warranty does not cover any parts or labor to correct any defect caused by negligence, accident or improper use, maintenance, installation, service or repair, including but not limited to improper removal and reinstallation (whether in the unit or at a remote location) of the condensing unit.

***The remedies described above for each warranty are the only ones which Sub-Zero will provide, either under these warranties or under any warranty arising by operation of law. Sub-Zero will not be responsible for any consequential or incidental damages arising from the breach of these warranties or any other warranties, whether express, implied or statutory.***

Some states do not allow the exclusion or limitation of incidental or consequential damages, so the above limitation or exclusion may not apply to you. This warranty gives you specific legal rights and you may also have other legal rights which vary from state to state.

To receive parts and/or service and the name of the Sub-Zero authorized service representative nearest you, contact your Sub-Zero dealer or distributor or contact Sub-Zero Freezer Company, Service Department, P.O. Box 44130, Madison, Wisconsin, 53744-4130 or call (800)222-7820.







*Sub-Zero Freezer Company, Inc. 4717 Hammersley Road Madison, Wisconsin 53711 (800) 222-7820 or (608) 271-2233*