

**PLEASE READ ENTIRE INSTRUCTIONS BEFORE PROCEEDING.  
 INSTALLATION MUST COMPLY WITH ALL LOCAL CODES.**

The warming drawer is completely self-contained and ready for installation.  
 Power Supply: 120Volts, 15 Ampere, 60 Hz.

**IMPORTANT:** Save these instructions for the local electrical inspector's use.  
**INSTALLER:** Please leave these Installation Instructions with this unit for the owner.  
**OWNER:** Please retain these instructions for future reference.

**IMPORTANT:** Before turning on power, be sure that the control is turned to "OFF."

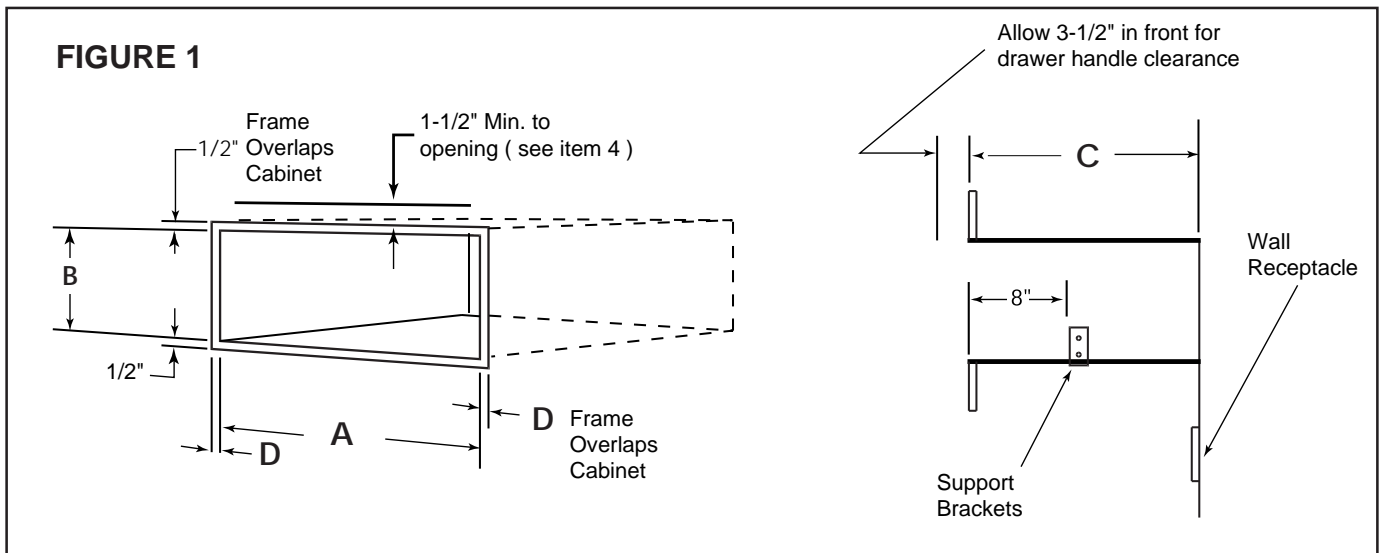

**Table 1**

	<b>MODEL WD24</b>	<b>MODEL WD27</b>	<b>MODEL WD30</b>
<b>DIM A</b>	22-1/2"	25-1/2"	25-1/2"
<b>DIM B</b>	9"	10"	10"
<b>DIM C</b>	20-1/4"	22-1/4"	22-1/4"
<b>DIM D</b>	3/8"	9/16"	2-1/8"

**TABLE 1:** Cut out Dimensions

**INSTALLING THE WARMING DRAWER**

1. The opening in the wall or cabinet should be A wide x B high x C deep minimum as shown in Table 1. Install two support brackets (provided) 8" from the front of the wall or cabinet at the same level as the bottom of the opening. (See Fig. 1)
2. Push unit into opening until it clears support brackets and supports its own weight.
3. Push unit tight against wall or cabinet and secure with four screws (provided). Two screws go into top two corners of front frame, the others go at the bottom of the front frame.
4. When stacking one drawer above the other or side-by-side installation, allow 1-1/2" between cutouts. If you desire a gap between the units, allow more space between the cutouts. Allow 2-1/2" between cutouts when installing the warming drawer under a wall oven.

## ELECTRICAL REQUIREMENTS & GROUNDING INSTRUCTIONS

**THIS APPLIANCE MUST BE CONNECTED TO RECEPTACLE ON A CIRCUIT RATED 120 VOLTS, 15 AMPERE, 60 Hz.**

Always disconnect electric supply cord from wall outlet before servicing this appliance.

Observe all governing codes and ordinances when grounding. In the absence of these codes or ordinances observe National Electrical Code ANSI/NFPA No. 70 Current Issue.

This appliance is factory equipped with a power supply cord with a three-prong grounding plug. **IT MUST BE PLUGGED INTO A MATING GROUNDING TYPE RECEPTACLE, CONNECTED TO A CORRECTLY GROUNDED 120 VOLT CIRCUIT.** If the circuit does not have a grounding type receptacle, it is the responsibility and obligation of the installer or user to have the existing receptacle changed to a properly grounded and polarized receptacle in accordance with all applicable local codes and ordinances by a qualified electrician. In the absence of local codes and ordinances, the receptacle replacement shall be in accordance with the National Electrical Code. **THE THIRD GROUND PRONG SHOULD NOT, UNDER ANY CIRCUMSTANCES, BE CUT OR REMOVED.** See Fig. A.

If there is any doubt as to whether the wall receptacle is properly grounded, the customer should have it checked by a qualified electrician.

Cold water pipe must have metal continuity to the electrical ground and not be interrupted by plastic, rubber or other electrically insulating connectors (including water meter or pump) without adding a jumper wire at these connections. See Fig. B.

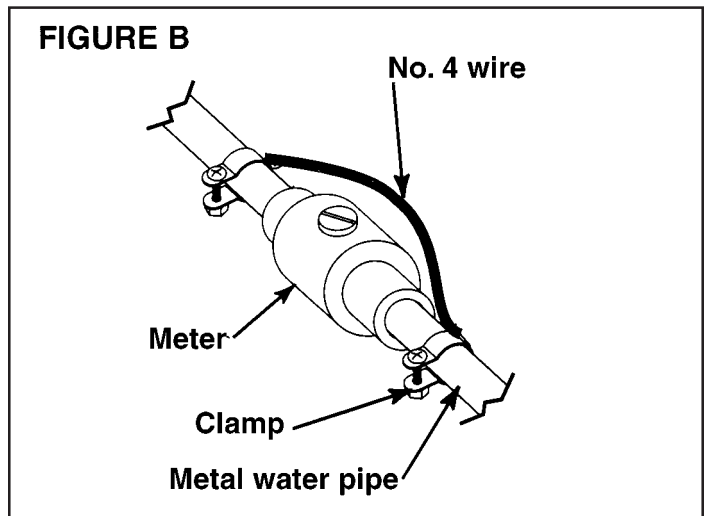
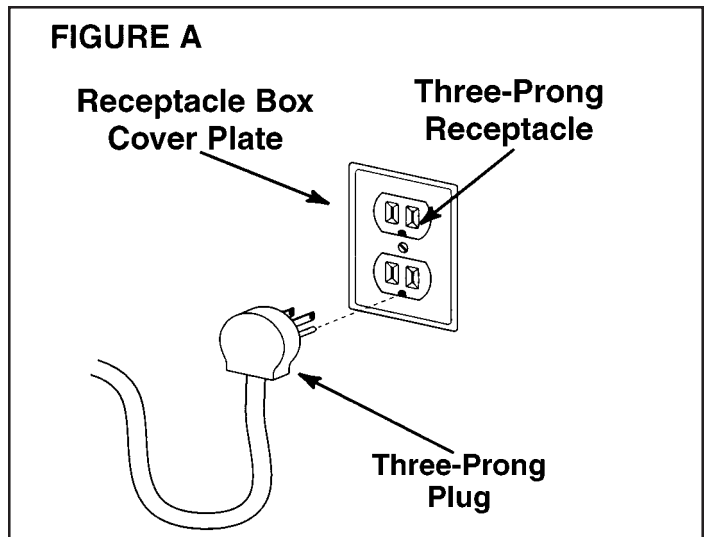

## PROCEDURE FOR CUSTOM WOOD DOOR FRONT

Construction of the Warming Drawer door is such that, the glass panel can be replaced with a custom wood panel to match other kitchen decor.

The glass panel can be replaced with a custom panel. Remove the drawer as noted in the Care & Use manual. Remove six screws securing the glass pack to the front of the drawer from the inside. Separate the glass pack from the drawer.

Place the glass pack on a flat surface (glass down) with the handle overhanging the surface; remove the two screws securing the handle. Once these screws are removed, the glass panel can be separated from the support. Install the lens into the 1/2" diameter hole at the bottom front of the wood panel and press retainer clip on back.

Attach the wood panel to the support using two wood screws through the handle mounting holes into the pilot holes on the back side of the wood panel. Re-assemble this support assembly to the drawer replacing the six screws. Then, install the drawer back into the slides as noted in the Care & Use Manual.

The custom wood panel must have all four edges finished because they are exposed, The back of the wood must be sealed to prevent moisture in the drawer

from damaging it. The custom wood panel's dimensions are A X B overall. Refer to Fig. 2 and Table 2 for panel dimensions.

Changes in construction or equipment may be made from time to time by the manufacturer without incurring any obligation.

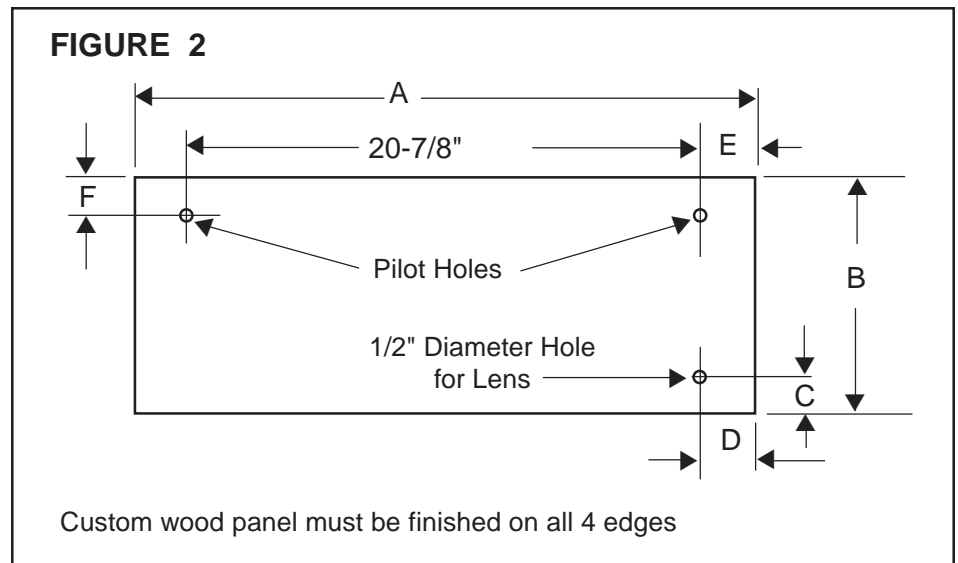

<b>DIM.</b>	<b>WD 24</b>	<b>WD27</b>	<b>WD30</b>
A	23-1/2	26-7/8	29-7/8
B	10-1/4	11-1/4	11-1/4
C	1-1/4	1-1/4	1-1/4
D	1-1/4	1-3/8	2-7/8
E	1-5/16	3	4-1/2
F	2-1/4	2-1/4	2-1/4

---

Specifications are for planning purposes only. Refer to installation instructions and consult your countertop supplier prior to making counter opening. Consult with a heating and ventilating engineer for your specific ventilation requirements. For the most detailed information, refer to installation instructions accompanying product or write Thermador indicating the model number.

Thermador reserves the right to change specifications or design without notice. Some models are certified for use in Canada. Thermador is not responsible for products which are transported from the United States for use in Canada. Check with your local Canadian distributor or dealer. Thermador, 5551 McFadden Avenue, Huntington Beach, CA 92649.

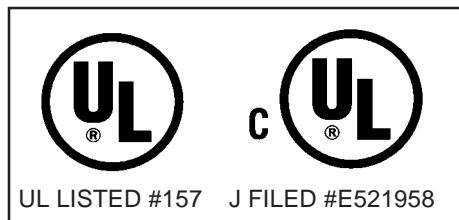

**Thermador**<sup>®</sup>  
CORPORATION

5551 McFadden Avenue, Huntington Beach, CA 92649 • 800/735-4328  
ECO12234 • 14-07-380F • © Thermador Corporation 1998 • Litho U. S. A. 6/99