

600
SERIES

INSTALLATION GUIDE



600
SERIES

INSTALLATION GUIDE





INSTALLATION GUIDE

Before you begin your installation of a Sub-Zero 600 Series unit, there are a few things you should take special care to observe. By reading these introductory instructions carefully, you will make the installation procedure easier, problem-free and, most important, safe.

First, as you follow these installation instructions, take particular note of the **WARNING!** and **CAUTION!** symbols when they appear. This information is important for the safe and efficient installation of this Sub-Zero.

⚠ WARNING

alerts you to a hazard that may cause serious injury or death if precautions are not followed.

⚠ CAUTION

signals a hazard where minor injury or product damage may occur if you do not follow instructions.

Also, The printed instructions may signal an **IMPORTANT NOTE**, which highlights information that is especially important for a problem-free installation.

Second, make sure that the actual equipment that was shipped to you matches the design you are expecting to install. Sub-Zero 600 Series models offer the following design alternatives: Framed, Overlay, Glass Door Models and Stainless Steel which is available in three finishes: classic, platinum and carbon stainless steel.

Each of these design options has specific installation requirements, which means it is vital that the unit match your planning and space needs. Before you begin, check the exact model number you need against the model numbers on the shipping carton.

- Stainless steel (classic, platinum and carbon finishes) and glass door units are packed in cartons with a gray cap and white lettering identifying them as stainless steel. The stainless steel unit will have a wrapped door, 1" (25 mm) diameter handles and heavy-duty stainless steel louvered grille.
- Framed and glass door units are packed in crates with a white cap and blue lettering identifying them as framed. The framed unit will have an extruded handle and a louvered grille.
- Overlay and glass door units are packed in cartons with a blue cap and white lettering identifying them as overlay. The unit is shipped with no handle hardware (hardware is supplied at the site to match cabinetry at the installation) and a two-part panel grille frame without a panel.

If the unit you receive does not match your requirements, contact your Sub-Zero dealer.

PRE-INSTALLATION SPECIFICATIONS

PREPARING THE SPACE

Step 1: First, make sure that the opening where the Sub-Zero is to be installed is properly prepared. Refer to the Pre-Installation Specifications illustrations and chart to be sure the space dimensions, electrical service and plumbing are correct for the model you are about to install.

Step 2: If you are installing units side by side, a separating filler strip is recommended. Add the filler strip width to the finished rough opening dimension. Complete the installation with Anchoring Kit #4-20-090-0, see page 17.

IMPORTANT NOTE: To operate properly, the door must open a minimum of 90°. Use a minimum 2" (51 mm) filler in corner installations to assure a 90° door opening. Allow enough clearance in front of the unit for full door swing.

IMPORTANT NOTE: Make sure the floor under the refrigerator is level with the surrounding finished floor. Protect a finished floor with plywood, cardboard or some other suitable material before moving the refrigerator across it.

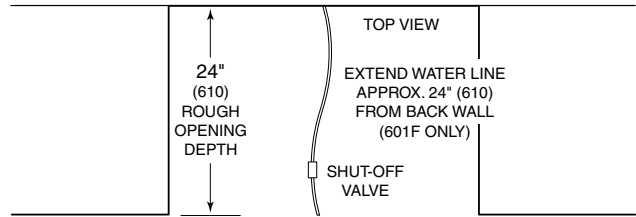

NOTE: Dimensions in parentheses are in millimeters.

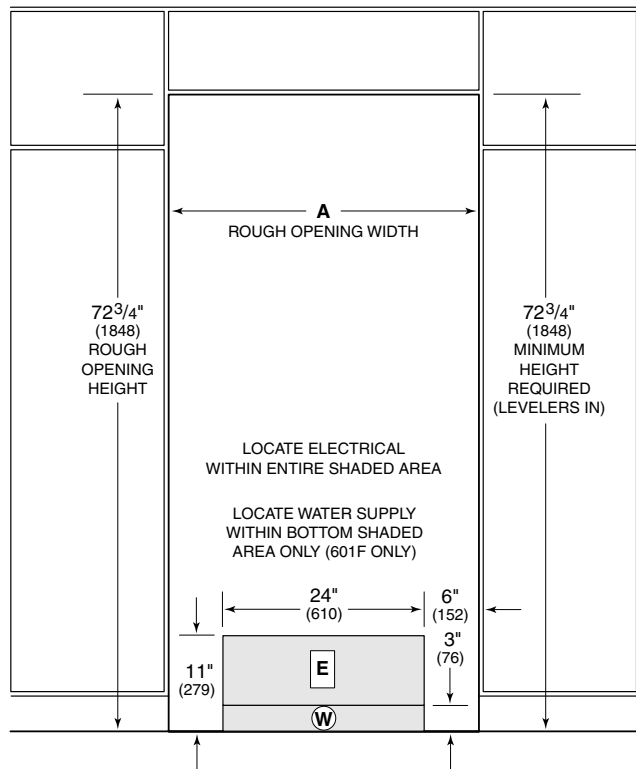

Pre-Installation Specifications – Models 601R, 601RG and 601F

600 SERIES

PRE-INSTALLATION SPECIFICATIONS

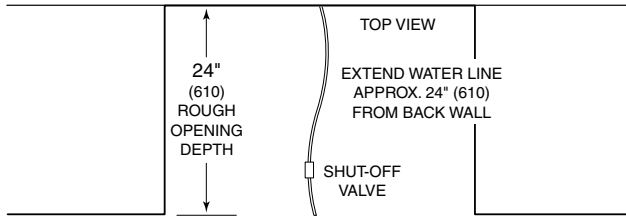

NOTE: Dimensions in parentheses are in millimeters.

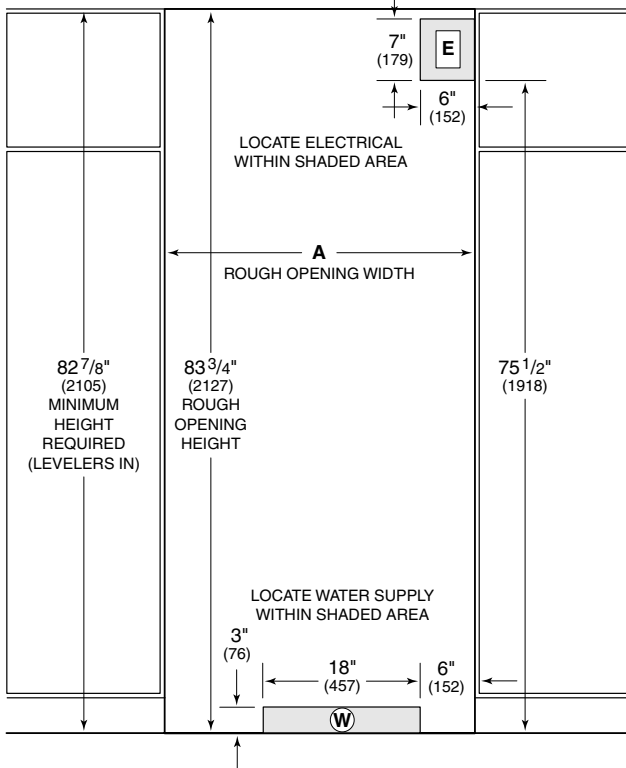

Pre-Installation Specifications – Models 611, 611G, 650, 650G, 561, 642, 680, 632 and 690

	Finished Rough Opening Width (A)	Minimum Door Clearance (B)
Model 601R	35 1/2" (902)	36 1/16" (916)
Model 601RG	35 1/2" (902)	36 1/16" (916)
Model 601F	35 1/2" (902)	36 1/16" (916)
Model 611	29 1/2" (749)	30 1/8" (765)
Model 611G	29 1/2" (749)	30 1/8" (765)
Model 650	35 1/2" (902)	36 1/16" (916)
Model 650G	35 1/2" (902)	36 1/16" (916)
Model 561	35 1/2" (902)	20 3/4" (527)
Model 642	41 1/2" (1054)	25 9/16" (649)
Model 680	41 1/2" (1054)	25 9/16" (649)
Model 632	47 1/2" (1207)	29 1/4" (743)
Model 690	47 1/2" (1207)	29 1/4" (743)

NOTE: Dimensions in parentheses are in millimeters.

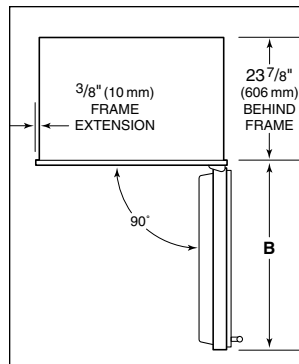

Minimum Door Clearance at 90° – Models 601R, 601RG, 601F, 611, 611G, 650 and 650G

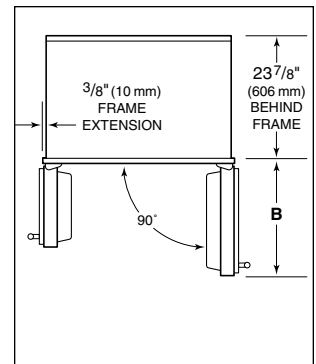

Minimum Door Clearance at 90° – Models 561, 642, 680, 632 and 690

PREPARING ELECTRICAL CONNECTIONS

Step 3: To prepare the electrical system, rough in the electrical outlet following the Pre-Installation Specifications. You will need a 115 volt, 60 Hertz electrical supply. Dedicate a separate 15 amp fuse or circuit breaker to the Sub-Zero unit, and follow any local codes that apply.

The Sub-Zero unit comes with a power supply cord with a three-prong grounding plug. The refrigerator must be plugged into a mating three-prong wall receptacle grounded in accordance with the National Electrical Code and local codes.

⚠ WARNING

Do not use an extension cord, or two prong adapter. Electrical ground is required on this appliance.

Do not under any circumstances remove the power supply cord ground prong.

PREPARING PLUMBING CONNECTIONS

Step 4: For units with automatic ice makers, first rough in the water supply line. Connect a 1/4" (6 mm) copper line to the house supply. Use an easily accessible shutoff valve between the supply and the refrigerator. This is usually about 6" (152 mm) from the compression fitting. The ice maker operates on water pressure of 20 to 100 PSI.

If the local water supply has high levels of sediment, consider adding an in-line filter. But don't use a self-piercing valve. See your Sub-Zero dealer for a saddle valve kit, ask for part number 4-20-088-0.

Good water is important for good ice quality. It is not recommended that the ice maker be connected to a softened water supply. Water softener chemicals, such as salt from a malfunctioning softener, can damage the ice maker mold and lead to poor ice quality. If a softened water supply cannot be avoided, it is important that the water softener be well maintained and operating properly.

Reverse osmosis systems can be used, provided there is a consistent water pressure of 20 to 100 PSI supplied to the water valve at all times.

Route the water line through the floor within 1/2" (13 mm) from the wall and no higher than 3" (76 mm) from the floor. If the water supply is brought in from behind the unit, route the water line through the wall no more than 3" (76 mm) from the floor. In either case, allow at least three feet of excess copper tubing outside the wall or floor for easy connection to the refrigerator.

UNPACKING THE SUB-ZERO

Step 5: Uncrate the unit, remove its wood base and discard the shipping bolts that hold the wood base to the bottom of the refrigerator. Remove all packing materials and tape as well. Do not discard the kickplate. Also, do not discard the anti-tip kit and hardware, because you may need them to block your installation. Next, retract the front leveler legs to let you move the unit more easily during installation.

To reduce the possibility of the unit tipping forward, position the front levelers flat on the floor. Extend these legs when the unit is finally positioned.

⚠ WARNING

Keep door(s) and drawer(s) taped closed while moving unit.

REMOVING THE GRILLE

Step 6: Remove the grille in order to get to the power cord and move the unit through doorways. For framed and stainless steel Models 611, 611G, 650, 650G, 642, 680, 632 and 690, remove three counter-sunk grille screws and cut the red nylon shipping strap. NOTE: Grille screws are accessed with door(s) open. Then tilt the grille forward and release the springs from behind the grille. See illustration 2.

For Models 601R, 601RG and 601F (framed and overlay), remove the two black screws in the lowest louver in the grille. Tilt the bottom of the grille out and away. It'll release from the top of the grille. See illustration 3.

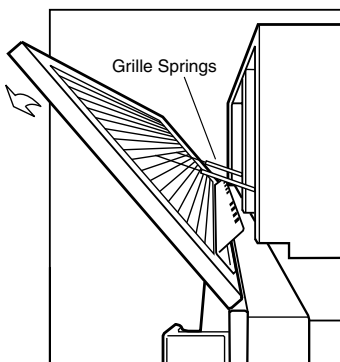

Illus. 2

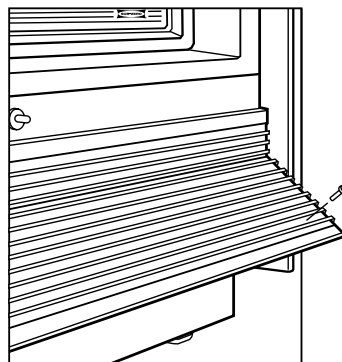

Illus. 3

For Models 601R, 601RG and 601F (stainless steel), the lower grille snaps out by pulling forward on the bottom of the grille.

If you're installing overlay Models 611, 611G, 650, 650G, 642 or 632, first remove the inner grille panel assembly, as shown in illustration 4. Lift up, then pull out at the bottom, pull the top section down and out of the top key slot. Next, remove the five mounting screws that hold the outer grille panel assembly to the top compartment. See illustration 5.

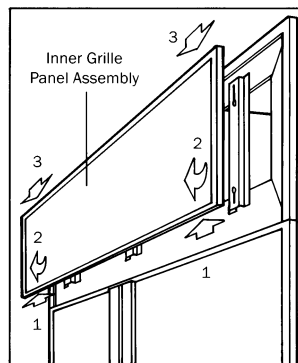

Illus. 4

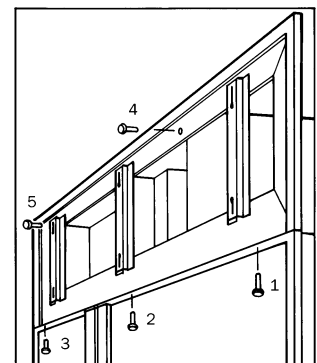

Illus. 5

BLOCKING FOR SAFETY

⚠ WARNING

To prevent the unit from tipping forward and provide a stable installation, the unit must be secured in place with an anti-tip device.

Step 7: If there is a solid soffit above the unit with clearance between the unit and the soffit of 1" (25 mm) or less, you won't need to block the unit. See illustration 6. But for installations with clearances of more than 1" (25 mm), you must block the unit.

Use the anti-tip kit (wood block and hardware) provided with the shipping crate. Locate and mark two wall studs against the wall where the refrigerator will be located. Next, locate the proper height to clear the unit. The space between the unit top and the bottom of the wood block must not be more than 1/4" (6 mm).

Position the wood block over the unit and use the screws and "L" brackets to lock it in place. Make sure the screws extend a minimum of 7/8" (22 mm) into each of the two wall studs. Make sure the wood block extends at least 3" (76 mm) over the unit and is securely in place. Refer to illustration 7.

Using the front and rear levelers, raise the unit until it makes contact with the wood block.

Make sure that the front levelers are firmly on the floor, to reduce the possibility of the cabinet tipping forward.

IMPORTANT NOTE: If at all possible, keep door(s) closed on the unit until it is properly anchored.

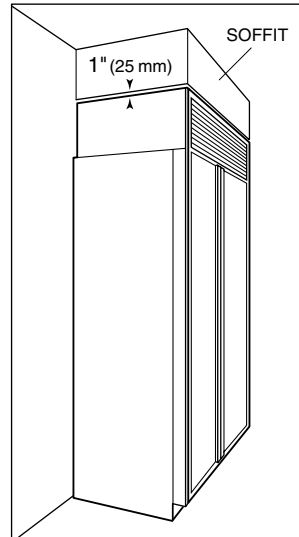

Illus. 6

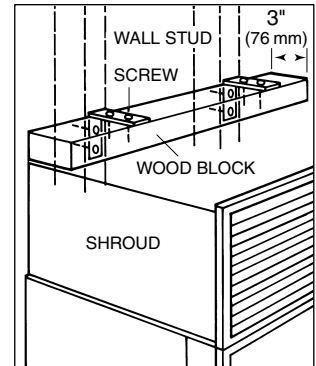

Illus. 7

COMPLETING THE INSTALLATION

⚠ CAUTION

Protect any finished flooring before moving the unit in place. All full size Sub-Zero models are equipped with rollers, so you can easily move the unit into place. If for any reason the unit has been laid on its back or side, you must allow the unit to stand upright for a minimum of 24 hours before connecting power.

Step 8: To complete the installation, first shut off power to the wall outlet. Plug into a 15 amp grounded outlet and roll the unit into position under the wood block or soft-fit. Now you have to connect the ice maker water line. Remove the 1/4" (6 mm) compression fitting from its plastic bag and join the water supply line to the solenoid valve.

If desired, the water valve can be removed from mounting bracket to gain easier access to water connection, as shown in illustration 8. Purge the line before making the final connection. Illustration 9 applies only to Models 680 and 690.

IMPORTANT NOTE: Turn on the water supply and check all fittings for leaks. Make certain the electrical harness is attached to the solenoid.

In areas with water of high mineral content, the use of an in-line water filter is recommended. Make sure the filter is positioned and accessible for replacement when necessary.

IMPORTANT NOTE: Let your customer know that the ice maker will not fill with water immediately, and that the first three batches of ice produced should be discarded. Allow 24 hours to get proper ice production.

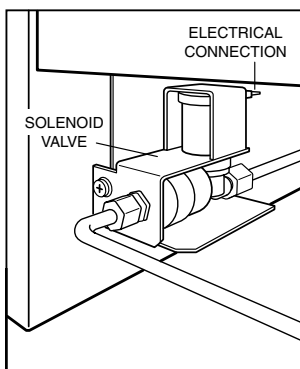

Illus. 8

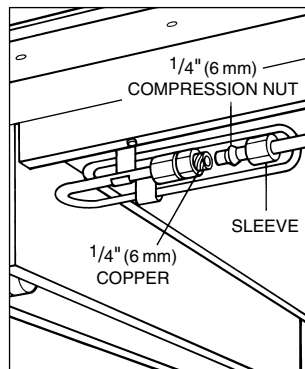

Illus. 9

Step 9: Now, level the unit. To adjust the height, turn the front leveling legs counterclockwise to lower it. Adjust the rear levelers from the front of the base. Turn the 5/16" (8 mm) hex bolt clockwise to raise the cabinet, counterclockwise to lower the cabinet. Refer to illustration 10. When the unit is leveled properly, or squared off, door adjustments are less likely to be necessary.

IMPORTANT NOTE: Be sure to reference leveling of the unit to the floor and not to surrounding cabinetry. This could effect the operation of the unit, such as door(s) not closing properly.

⚠ WARNING

To reduce the possibility of the cabinet tipping forward, the front levelers must be in contact with the floor.

Step 10: After the unit has been leveled, install the kickplate as shown in illustration 11. Be sure the drain pan is installed properly.

⚠ CAUTION

The kickplate must be removed for servicing. The floor cannot interfere with removal. Refer to label mounted on kickplate support for height clearance.

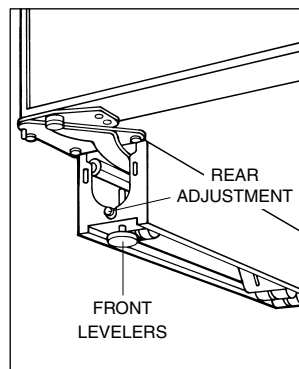

Illus. 10

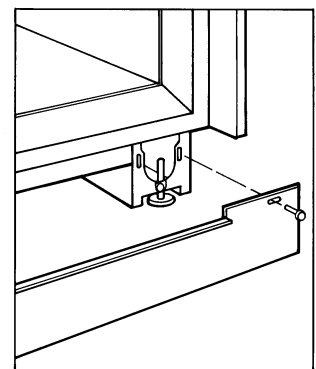

Illus. 11

Step 11: Replace the grille by reversing the procedure in Step 6 and turn the power back on. If you're using a panel grille, refer to Installing Overlay Grille Panels, page 13.

INSTALLING PANELS

Before you begin installing panels, refer to the Panel Specifications charts, and be sure you are working with the Sub-Zero panel design called for in your installation plans. If your customer has chosen the stainless steel design, the unit has been shipped complete with a finished stainless steel look. No panels or handle hardware are necessary to install. In your final preparation for stainless steel units use a stainless steel cleaner to remove any marks. Abrasive cleaners should NOT be used, as they may scratch the surface.

If your customer has ordered either framed or overlay units, you will be installing panels to give the unit the custom Sub-Zero look.

FRAMED PANELS

Step 12: If your customer has chosen a framed design application, first remove the door handles to install the front panels. The handle screws are hidden by a magnet backed trim molding. Remove the molding using a piece of tape to pull it away from the handle and expose the handle screws. The molding will bend at the center so that you can remove it. See illustration 12.

Step 13: If the thickness of the custom panels is less than a 1/4" (6 mm), back them up with a sheet of shim material to build the total thickness to a 1/4" (6 mm). If the panel is thicker than a 1/4" (6 mm), rout an edge around the panel to get a proper fit. Keep in mind that the weight of each panel cannot exceed 50 lbs. (22.7 kg). Refer to the Framed Panel Specifications chart on page 12 for panel dimensions. Additional panel design information can be found in the Sub-Zero Design Guide.

IMPORTANT NOTE: On all models except Models 680 and 690, routing, recessing or optional extended handles may be required on raised panels for finger clearance under the handle. See Accommodations for Raised Panels, page 11.

Step 14: With a Phillips screwdriver, remove the handles from the freezer and refrigerator doors. Slide the panel into the frame on the door. With the panel in position, replace the handles. Be sure the panel is inserted completely into the channel for proper fit and alignment. See illustration 13. Next, replace the trim moldings by inserting the top, then the bottom into the handle channel. Release the middle and set the magnets.

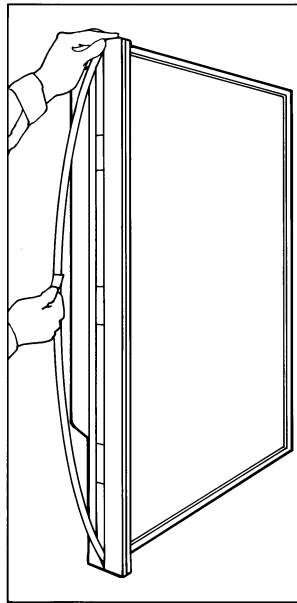

Illus. 12

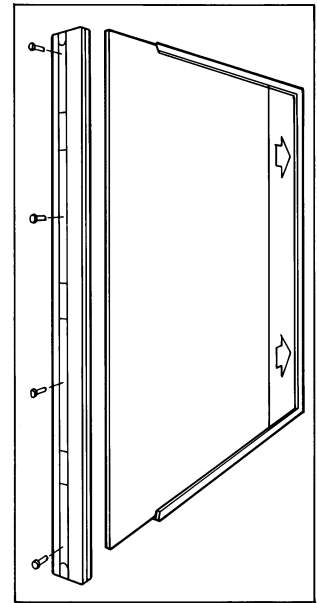

Illus. 13

INSTALLING PANELS MODELS 680 AND 690

If you're installing a Model 680 or 690 refrigerator/freezer, first remove the door handle and trim. The screws are hidden by a magnet-backed trim molding. Remove the molding using a piece of tape to pull it away from the handle and expose the handle screws. The trim molding will bend out at the center to allow you to remove it.

With a Phillips screwdriver, remove the door handles on freezer and refrigerator doors. The door handles also act as a door trim.

Remove the handle trim panels by sliding them out of the doors. Different colored handle trim panels and glasswells are available through your Sub-Zero dealer.

Next, remove the water and ice glasswell by removing the mounting screw. Then slide the glasswell up and pull it out. Remove the top and bottom trim fillers held on by the mounting screws, and the screws holding the vertical trim strip. Install the door panels by sliding them into the frame on the door. Refer to illustrations 14 and 15. With the door panels in place, reverse the steps to reassemble.

ACCOMMODATIONS FOR RAISED PANELS

You may have to rout, recess or use optional extended handles with some door panel designs to allow for finger clearance. This is particularly true if your unit has raised panels greater than 1/4" (6 mm) total thickness. Remember, there is a maximum weight limit of 50 lbs. (22.7 kg) per door panel as well.

Check the location of offset when you're using specific routing for the grip area only. Refer to the 600 Series section of the Sub-Zero Design Guide for a full-scale template of the standard full length handle and panel. Use this grid template to lay out your panel design for finger clearance when standard full length handles are used.

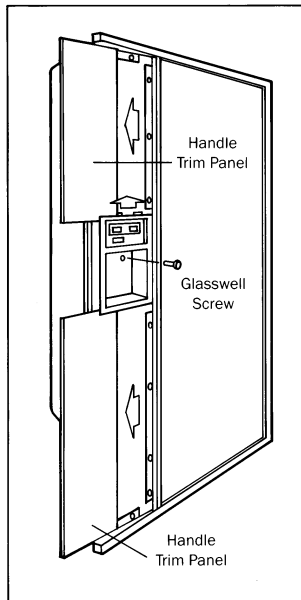

Illus. 14

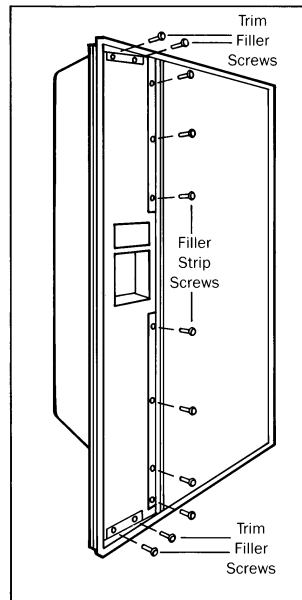

Illus. 15

FRAMED PANEL SPECIFICATIONS

	Refrigerator Panel		Freezer Panel		Handle Recess Location	
	(W)	(H)	(W)	(H)	(A)	(B)
Model 601R	34 ¹ / ₈ " (867)	58 ¹⁵ / ₁₆ " (1497)			29 ¹⁵ / ₃₂ " (749)	
Model 601RG	34 ¹ / ₈ " (867)	58 ¹⁵ / ₁₆ " (1497)			29 ¹⁵ / ₃₂ " (749)	
Model 601F			34 ¹ / ₈ " (867)	58 ¹⁵ / ₁₆ " (1497)	29 ¹⁵ / ₃₂ " (749)	
Model 611	28 ¹ / ₈ " (714)	48 ¹ / ₁₆ " (1221)	28 ¹ / ₈ " (714)	18 ³ / ₈ " (467)	24 ¹ / ₃₂ " (610)	14 ¹ / ₁₆ " (357)
Model 611G	28 ¹ / ₈ " (714)	48 ¹ / ₁₆ " (1221)	28 ¹ / ₈ " (714)	18 ³ / ₈ " (467)	24 ¹ / ₃₂ " (610)	14 ¹ / ₁₆ " (357)
Model 650	34 ¹ / ₈ " (867)	48 ¹ / ₁₆ " (1221)	34 ¹ / ₈ " (867)	18 ³ / ₈ " (467)	24 ¹ / ₃₂ " (610)	17 ¹ / ₁₆ " (433)
Model 650G	34 ¹ / ₈ " (867)	48 ¹ / ₁₆ " (1221)	34 ¹ / ₈ " (867)	18 ³ / ₈ " (467)	24 ¹ / ₃₂ " (610)	17 ¹ / ₁₆ " (433)
Model 561	19 ¹ / ₈ " (486)	67 ¹¹ / ₁₆ " (1719)	14 ⁵ / ₈ " (371)	67 ¹¹ / ₁₆ " (1719)	38 ⁵ / ₃₂ " (981)	
Model 642	24" (610)	67 ¹¹ / ₁₆ " (1719)	15 ⁵ / ₈ " (397)	67 ¹¹ / ₁₆ " (1719)	38 ⁵ / ₃₂ " (981)	
Model 680	16 ⁷ / ₈ " (429)	67 ¹¹ / ₁₆ " (1719)	12 ¹³ / ₁₆ " (235)	67 ¹¹ / ₁₆ " (1719)		
Model 632	27 ¹¹ / ₁₆ " (703)	67 ¹¹ / ₁₆ " (1719)	17 ¹⁵ / ₁₆ " (456)	67 ¹¹ / ₁₆ " (1719)	38 ⁵ / ₃₂ " (981)	
Model 690	20 ⁹ / ₁₆ " (522)	67 ¹¹ / ₁₆ " (1719)	15 ¹ / ₈ " (384)	67 ¹¹ / ₁₆ " (1719)		

	Window Location Dimensions	
	(C)	(D)
Model 601RG	4 ³ / ₈ " (111)	13 ³ / ₈ " (340)
Model 611G	4 ³ / ₈ " (111)	4 ³ / ₈ " (111)
Model 650G	4 ³ / ₈ " (111)	4 ³ / ₈ " (111)

	Window Cut-out Dimensions	
	Model 601RG	25 ³ / ₈ " (645) W x 41 ³ / ₁₆ " (1046) H
Model 611G	19 ³ / ₈ " (492) W x 39 ⁵ / ₁₆ " (999) H	
Model 650G	25 ³ / ₈ " (645) W x 39 ⁵ / ₁₆ " (999) H	

	Trim Panel Dimension (E)	
	Model 680 and 690	6 ⁷ / ₈ " (175) W x 25 ⁷ / ₃₂ " (641) H x .05" (1.3) thick

	Trim Panel Dimension (F)	
	Model 680 and 690	6 ⁷ / ₈ " (175) W x 31 ⁷ / ₃₂ " (793) H x .05" (1.3) thick

	Trim Panel Dimension (G)	
	Model 680 and 690	2 ⁹ / ₁₆ " (65) W x 67 ¹¹ / ₁₆ " (1719) H x .05" (1.3) thick

NOTE: Dimensions in parentheses are in millimeters.

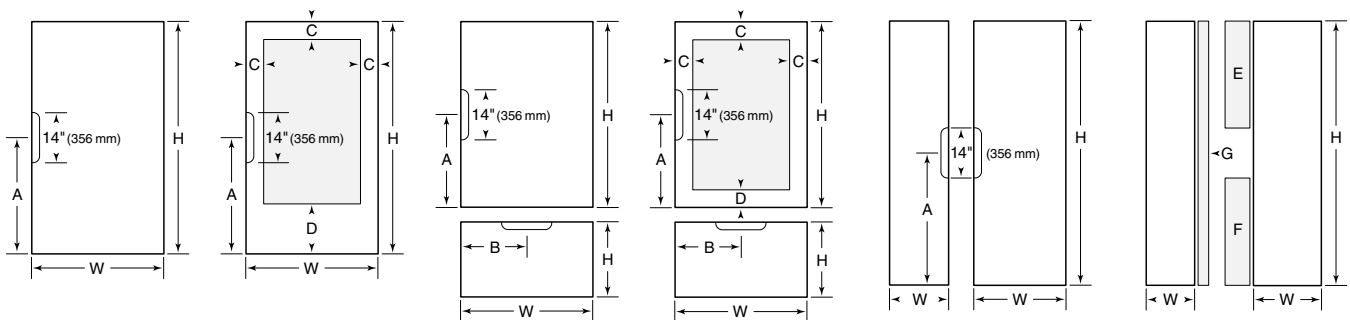

Models 601R and 601F

Model 601RG

Models 611 and 650

Models 611G and 650G

Models 561, 642 and 632

Models 680 and 690

INSTALLING OVERLAY PANELS

If your customer has chosen overlay decorative door panels and grille panel, the unit will be shipped without door handles and hardware. The cabinet manufacturer or designer will provide handle hardware at the job site to match the overall decorating scheme. To install overlay panels, first remove the magnet backed trim molding using a piece of tape to pull it away from the frame and expose the frame screws. The molding will bend at the center so that you can remove it.

Remove the frame by removing the four screws holding it in place. The door channel is now ready to accept the overlay paneling.

Sub-Zero allows a 1/4" (6 mm) space to slide the backing material into place in the frame. If your material is thicker than a 1/4" (6 mm), either rout an edge around the panel to get a proper fit or mount the decorative overlay panel on a sheet of 1/4" (6 mm) thick material and insert the backing material into the channel.

You must allow for .10" (2.5 mm) space between the backer board and the decorative panel, so the panel will slide easily into the door frame. Keep in mind that the weight of each panel assembly cannot exceed 50 lbs. (22.7 kg). Refer to the Overlay Panel Specifications chart on page 14 for exact sizing of all three panels. Additional panel design information can be found in the Sub-Zero Design Guide.

IMPORTANT NOTE: The size of the overlay panel is critical. It must fit over the door frame.

Step 15: Install the handle hardware before inserting the panel. We recommend larger D-style pulls. The use of small, one-piece knobs is not recommended.

If you use screws with thick heads, you will need to countersink the screws into the backer panel before sliding the assembly into place.

Step 16: Slide the panel into the frame on the door. With the panel in position, replace the frame end. Be sure the panel is inserted completely into the channel for proper fit and alignment. Next, replace the trim molding by inserting the top, then the bottom into the frame channel. Release the middle and set the magnets.

INSTALLING OVERLAY GRILLE PANELS

Remove the inner grille panel assembly (see Step 6). Remove the top two corner screws and pull away the top frame. Slide the panel into position in the grille frame. If you are using a grille panel 1/4" (6 mm) or thinner, you will need to install a filler.

Reattach the top frame by reinstalling the two top corner screws. Install the inner grille panel assembly onto the unit, as described in Step 6.

Refer to the Overlay Grille Panel Specifications chart on page 15 for exact sizing of all three panels. Additional panel design information can be found in the Sub-Zero Design Guide.

OVERLAY PANEL SPECIFICATIONS

Refrigerator Panels:	Refrigerator Overlay Panel		Refrigerator Spacer Panel		Refrigerator Backer Panel	
	(W)	(H)	(W)	(H)	(W)	(H)
Model 601R / 601RG	34 ⁷ / ₁₆ " (875)	59 ¹ / ₄ " (1505)	33 ¹ / ₂ " (851)	58 ⁵ / ₁₆ " (1497)	34 ¹ / ₈ " (867)	58 ¹⁵ / ₁₆ " (1497)
Model 611 / 611G	28 ⁷ / ₁₆ " (722)	48 ³ / ₈ " (1229)	27 ¹ / ₂ " (699)	47 ⁷ / ₁₆ " (1205)	28 ¹ / ₈ " (714)	48 ¹ / ₁₆ " (1221)
Model 650 / 650G	34 ⁷ / ₁₆ " (875)	48 ³ / ₈ " (1229)	33 ¹ / ₂ " (851)	47 ⁷ / ₁₆ " (1205)	34 ¹ / ₈ " (867)	48 ¹ / ₁₆ " (1221)
Model 561	19 ⁷ / ₁₆ " (494)	68" (1727)	18 ¹ / ₂ " (470)	67 ¹ / ₁₆ " (1703)	19 ¹ / ₈ " (486)	67 ¹¹ / ₁₆ " (1719)
Model 642	24 ⁵ / ₁₆ " (618)	68" (1727)	23 ³ / ₈ " (594)	67 ¹ / ₁₆ " (1703)	24" (610)	67 ¹¹ / ₁₆ " (1719)
Model 632	28" (711)	68" (1727)	27 ¹ / ₁₆ " (687)	67 ¹ / ₁₆ " (1703)	27 ¹¹ / ₁₆ " (703)	67 ¹¹ / ₁₆ " (1719)

Freezer Panels:	Freezer Overlay Panel		Freezer Spacer Panel		Freezer Backer Panel	
	(W)	(H)	(W)	(H)	(W)	(H)
Model 601F	34 ⁷ / ₁₆ " (875)	59 ¹ / ₄ " (1505)	33 ¹ / ₂ " (851)	58 ⁵ / ₁₆ " (1497)	34 ¹ / ₈ " (867)	58 ¹⁵ / ₁₆ " (1497)
Model 611 / 611G	28 ⁷ / ₁₆ " (722)	18 ¹¹ / ₁₆ " (475)	27 ¹ / ₂ " (699)	17 ³ / ₄ " (451)	28 ¹ / ₈ " (714)	18 ³ / ₈ " (467)
Model 650 / 650G	34 ⁷ / ₁₆ " (875)	18 ¹¹ / ₁₆ " (475)	33 ¹ / ₂ " (851)	17 ³ / ₄ " (451)	34 ¹ / ₈ " (867)	18 ³ / ₈ " (467)
Model 561	14 ¹⁵ / ₁₆ " (379)	68" (1727)	14" (356)	67 ¹ / ₁₆ " (1703)	14 ⁵ / ₈ " (371)	67 ¹¹ / ₁₆ " (1719)
Model 642	15 ¹⁵ / ₁₆ " (405)	68" (1727)	15" (381)	67 ¹ / ₁₆ " (1703)	15 ⁵ / ₈ " (397)	67 ¹¹ / ₁₆ " (1719)
Model 632	18 ¹ / ₄ " (464)	68" (1727)	17 ⁵ / ₁₆ " (440)	67 ¹ / ₁₆ " (1703)	17 ¹⁵ / ₁₆ " (456)	67 ¹¹ / ₁₆ " (1719)

NOTE: Overlay panel design option is not available on Models 680 or 690.

Window Cutout Location:	(C)	(D)	Window Cutout Dimensions	
Model 601RG	4 ¹ / ₂ " (114)	13 ¹ / ₂ " (343)	Model 601RG	25 ⁷ / ₁₆ " (646) W x 41 ¹ / ₄ " (1048) H
Model 611G	4 ¹ / ₂ " (114)	4 ¹ / ₂ " (114)*	Model 611G	19 ⁷ / ₁₆ " (494) W x 39 ³ / ₈ " (1000) H
Model 650G	4 ¹ / ₂ " (114)	4 ¹ / ₂ " (114)*	Model 650G	25 ⁷ / ₁₆ " (646) W x 39 ³ / ₈ " (1000) H

NOTE: Dimensions in parentheses are in millimeters.

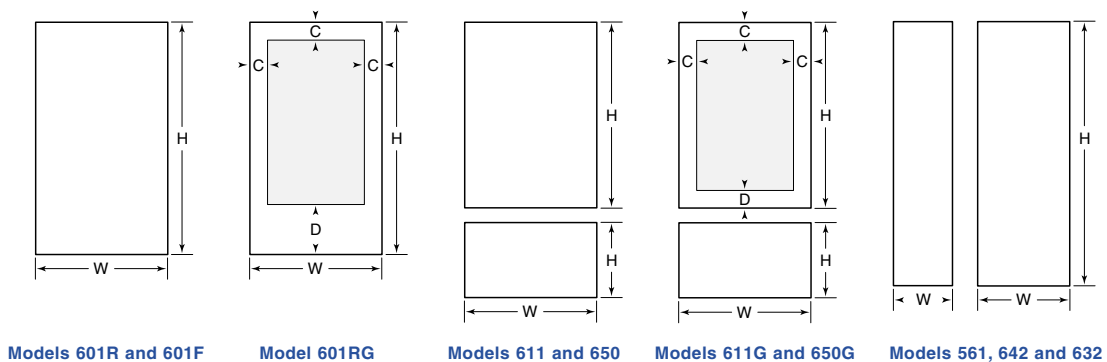

OVERLAY GRILLE PANEL SPECIFICATIONS

Grille Panel Width (W)	Overlay Panel	Spacer Panel	Backer Panel
Model 611	28 ⁷ / ₁₆ "(722)	27 ¹ / ₂ "(699)	28 ³ / ₁₆ "(716)
Model 611G	28 ⁷ / ₁₆ "(722)	27 ¹ / ₂ "(699)	28 ³ / ₁₆ "(716)
Model 650	34 ⁷ / ₁₆ "(875)	33 ¹ / ₂ "(851)	34 ³ / ₁₆ "(868)
Model 650G	34 ⁷ / ₁₆ "(875)	33 ¹ / ₂ "(851)	34 ³ / ₁₆ "(868)
Model 561	34 ⁷ / ₁₆ "(875)	33 ¹ / ₂ "(851)	34 ³ / ₁₆ "(868)
Model 642	40 ⁷ / ₁₆ "(1027)	39 ¹ / ₂ "(1003)	40 ³ / ₁₆ "(1021)
Model 680	40 ⁷ / ₁₆ "(1027)	39 ¹ / ₂ "(1003)	40 ³ / ₁₆ "(1021)
Model 632	46 ⁷ / ₁₆ "(1180)	45 ¹ / ₂ "(1156)	46 ³ / ₁₆ "(1173)
Model 690	46 ⁷ / ₁₆ "(1180)	45 ¹ / ₂ "(1156)	46 ³ / ₁₆ "(1173)

Grille Panel Height (H)	Overlay Panel	Spacer Panel	Backer Panel
10" Grille	9 ¹ / ₄ "(235)	8 ⁵ / ₁₆ "(211)	8 ¹⁵ / ₁₆ "(227)
11" Grille	10 ¹ / ₄ "(260)	9 ⁵ / ₁₆ "(237)	9 ¹⁵ / ₁₆ "(252)
12" Grille	11 ¹ / ₄ "(286)	10 ⁵ / ₁₆ "(262)	10 ¹⁵ / ₁₆ "(278)
13" Grille	12 ¹ / ₄ "(311)	11 ⁵ / ₁₆ "(287)	11 ¹⁵ / ₁₆ "(303)
14" Grille	13 ¹ / ₄ "(337)	12 ⁵ / ₁₆ "(313)	12 ¹⁵ / ₁₆ "(329)
15" Grille	14 ¹ / ₄ "(362)	13 ⁵ / ₁₆ "(338)	13 ¹⁵ / ₁₆ "(354)

NOTE: Dimensions in parentheses are in millimeters.

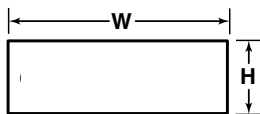

Overlay Grille Panel Specifications

OPTIONAL GRILLE PANEL – FRAMED APPLICATION

	Grille Panel Width (W)
Model 611	28 ³ / ₁₆ "(716)
Model 611G	28 ³ / ₁₆ "(716)
Model 650	34 ³ / ₁₆ "(868)
Model 650G	34 ³ / ₁₆ "(868)
Model 561	34 ³ / ₁₆ "(868)
Model 642	40 ³ / ₁₆ "(1021)
Model 680	40 ³ / ₁₆ "(1021)
Model 632	46 ³ / ₁₆ "(1173)
Model 690	46 ³ / ₁₆ "(1173)

	Grille Panel Height (H)
10" Grille	8 ¹⁵ / ₁₆ "(227)
11" Grille (standard)	9 ¹⁵ / ₁₆ "(252)
12" Grille	10 ¹⁵ / ₁₆ "(278)
13" Grille	11 ¹⁵ / ₁₆ "(303)
14" Grille	12 ¹⁵ / ₁₆ "(329)
15" Grille	13 ¹⁵ / ₁₆ "(354)

INSTALLING SIDE PANELS

If you're installing a unit with side panels, check with your installer or use one of the side panel installation options shown in illustration 17.

Drill three holes equidistant in a vertical section of the aluminum frame, and install pan head screws. Do not drill through model and serial number plate. Anchor the side panel with decorative screws or finishing nails from a local hardware store. Do not use adhesives. See illustration 16.

The dimensions given in illustration 17 are for typical wood side panels. If a 1/4" (6 mm) or less panel is used and inserted into the return channel extrusion, then a 24-1/4" (616 mm) size is necessary for width. The sheet must also be notched for grille and other brackets or screws that are in the return channel. This is only necessary on this application.

IMPORTANT NOTE: The use of side panels may change the width of your rough opening.

The overall height on the side panel will vary with the height of the grille being used. Make sure you know your finished height before cutting any panels.

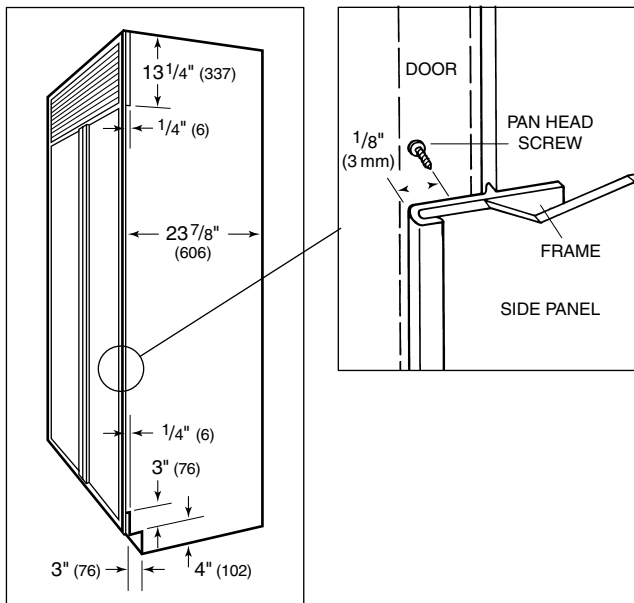

Illus. 16

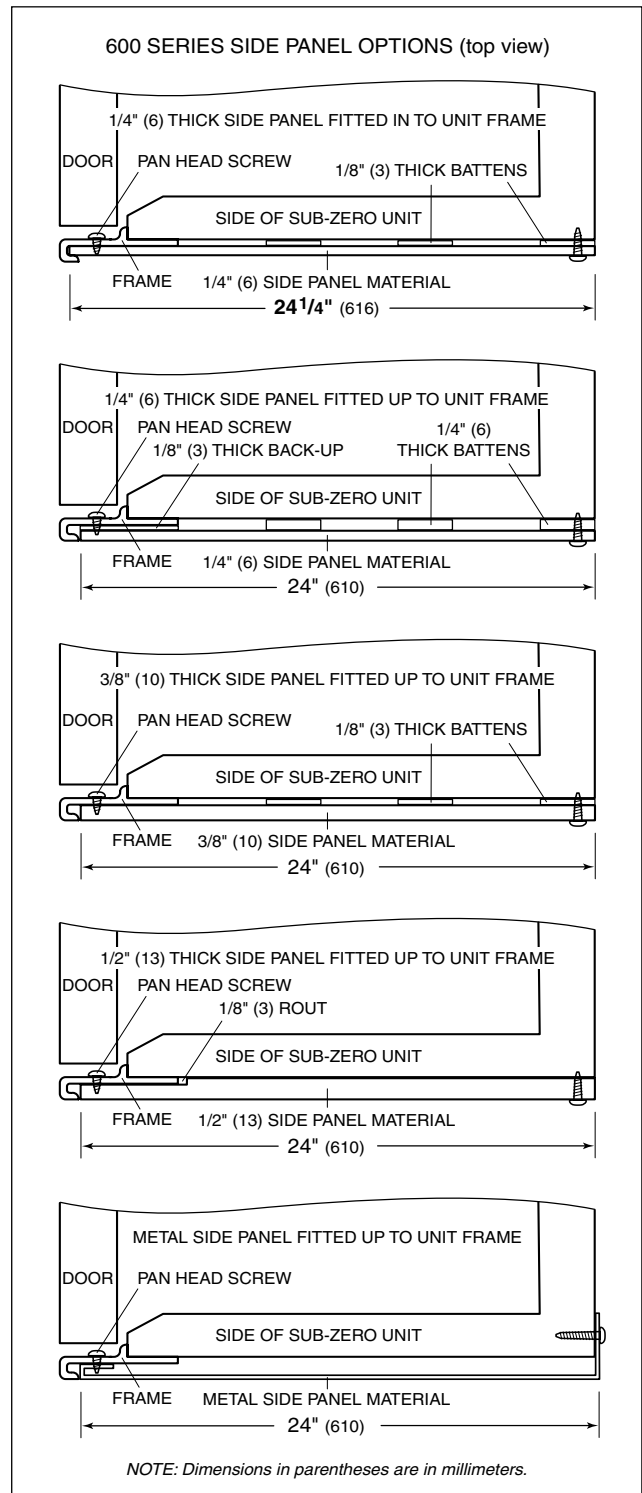

Illus. 17

ANCHORING THE UNIT

Step 17: After installing front and side panels, leveling, alignment and door adjustment, anchor the unit to the opening to assure a proper fit. The Sub-Zero Anchoring Kit #4-20-090-0 is available from your Sub-Zero dealer. Be sure to level and square the unit before anchoring it.

If two units are being tied together:

- Drill three 13/64" (5 mm) holes through the middle trim of both units.

⚠ CAUTION

Do not drill through the model and serial number plate.

- Using the Loctite on the screws, install the three Chicago screw posts.
- Recheck the units for level.
- Drill three 3/16" (5 mm) holes through both outer trims. See illustration 18.
- Using a 1/8" (3 mm) drill bit, drill into the cabinetry for a pilot hole.
- Install all six Sems to the cabinetry.

If you are fastening units to cabinetry:

- First, make sure units have been leveled and aligned, and doors adjusted.
- Drill three 3/16" (5 mm) holes through both outer trims as shown in illustration 19.
- Drill a 1/8" (3 mm) pilot hole into the cabinetry.
- Install all six Sems.

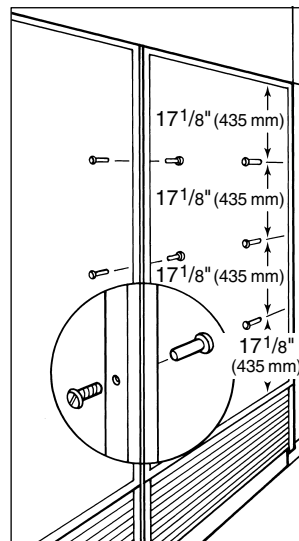

Illus. 18

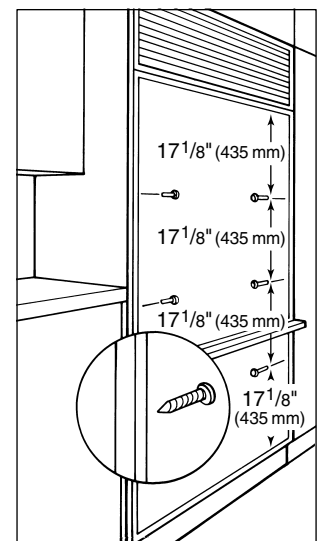

Illus. 19

ADJUSTING THE HINGES

Now check to make sure doors are properly adjusted. If not, adjust the top or bottom hinge by first removing and discarding the two small shipping screws. See illustration 20. Adjust the top door hinges left to right and in or out by loosening the three allen head screws. Adjust the bottom door hinge with a 1/8" (3 mm) allen wrench. Refer to illustration 21. The door will now be able to move left to right or in and out.

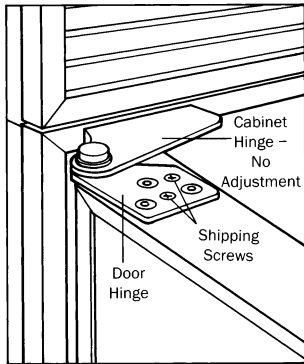

Illus. 20

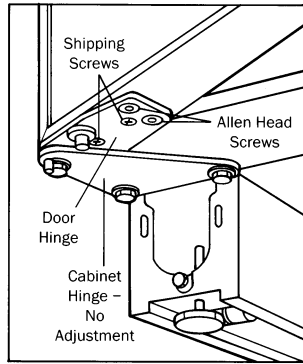

Illus. 21

90 DEGREE DOOR STOP

All 600 Series doors open to 130 degrees. For Models 611 and 650, if you would like to stop the door swing at 90 degrees, remove the door stop pin from the plastic package located behind the grille and insert it into the space provided on the top hinge plate. See illustration 22. For Models 611G and 650G, remove the door stop pin from the plastic package located behind the grille and insert it into the space provided on the hinge plate. See illustration 23.

Tighten firmly with a screwdriver. Optional 90° or 105° door stop kits for Models 601R, 601RG, 601F, 561, 642, 680, 632 and 690 are available through your Sub-Zero dealer.

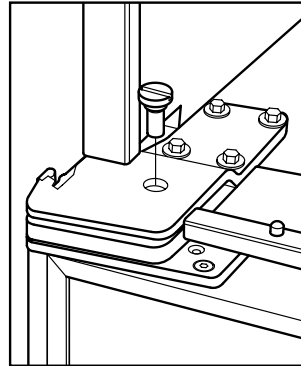

Illus. 22

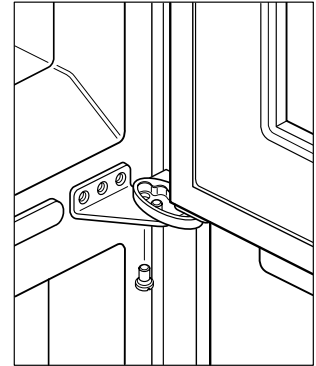

Illus. 23

600 SERIES

CHECKING THE RESULTS

That's it. You've completed the installation of a Sub-Zero 600 Series refrigerator/freezer. But you're not finished yet. Go over our checklist of installation steps.

- Has the packing material been removed?
- Turn the unit on first, is the unit operating properly? If not, is it plugged in? Is the control turned on?
- Is the water supply line connected to the compression fitting and not leaking?
- Has blocking been completed?
- Is the unit leveled properly on a solid floor?
- Has the drain pan been installed properly?
- Is the kickplate installed?
- Are the grille screws back in position?
- Are panels installed correctly?
- Are the doors adjusted for proper operation, sealing and alignment?
- Does your customer understand the unit's operation?
- Is the ice maker switch turned on?
- Have you given your customer the warranty package?

SERVICE FOR YOUR SUB-ZERO REFRIGERATION SYSTEM

If you need service, check the model and serial number on the plate at the top frame of the unit inside the door.

Contact a Sub-Zero Factory Authorized Service Center, a dealer, or Sub-Zero Freezer Company, Customer Service Dept., P. O. Box 44130, Madison, WI 53744-4130, call (800) 222-7820, or e-mail us at customerservice@subzero.com.

THINK SAFETY!

If you are storing or disposing of your old refrigerator, please do it safely.

Child entrapment accidents can be tragic.

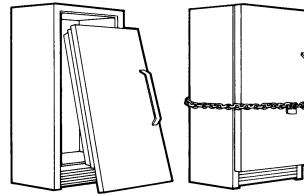

600



SUB-ZERO FREEZER COMPANY, INC.

4717 Hammersley Road • Madison, Wisconsin 53711
(800) 222-7820 • (608) 271-2233 • E-mail: customerservice@subzero.com